

SNACK-SIZED SERENITY

Building Instructions by Chris Doyle **Of www.ReasonablyClever.com**

I hope you find the following instructions useful!

This was my first attempt at using the MLCad design tools, so there are a few small glitches, but nothing major. Parts may appear a bit haphazardly, but they shouldn't move around any.

If you want the original MLCad file, it's available for download at Reasonably Clever.

First off, I'll list the parts you'll need for this project, then there are graphics showing you how to build the model every step of the way. Hopefully any frustrations you have with these instructions are lessened by having your own Hand-Held Serenity when you're done!

If you have questions or comments, please feel free to email me at Bat_hero@hotmail.com

A leaf in the wind,
Chris

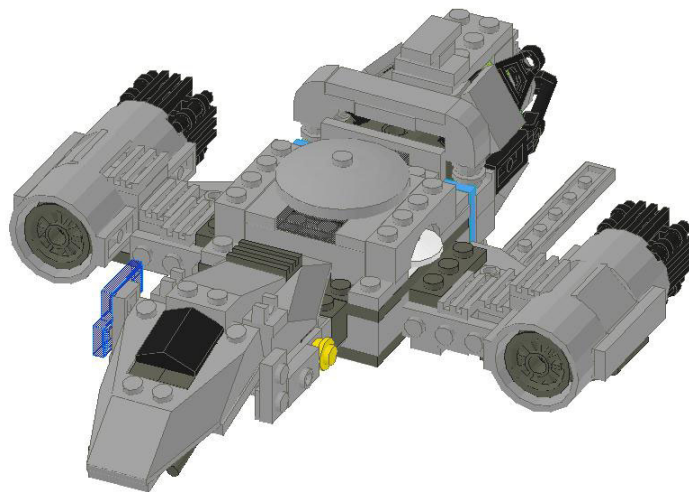

First, here's a full list of the parts that you'll need. I'll show this in two ways. First up, there is a pictographic view of the parts sorted by color and quantity. Following that, I've copied the text list with descriptions generated by the CAD program.

Light Grey Parts

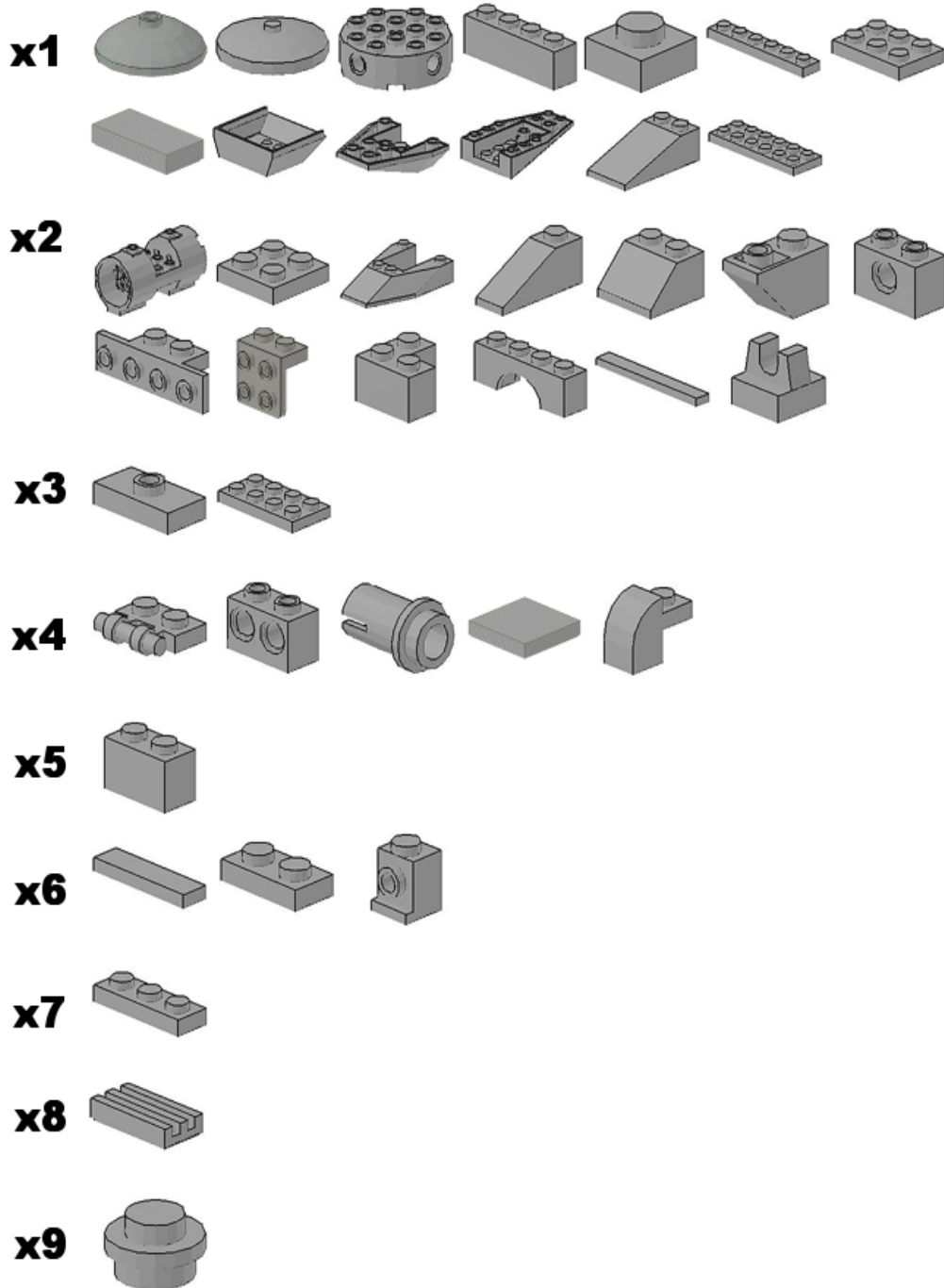

Dark Grey Parts

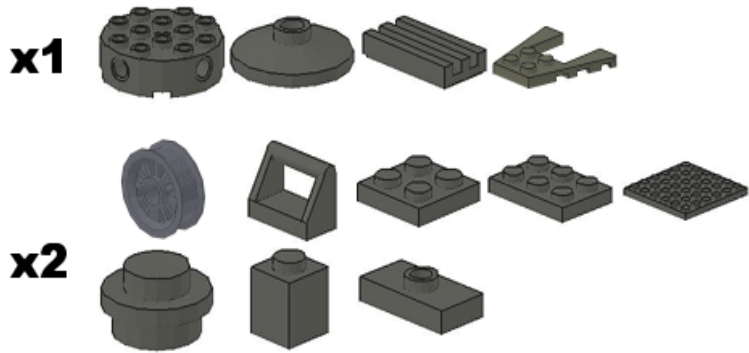

Dark Blue Grey Parts



Black Parts

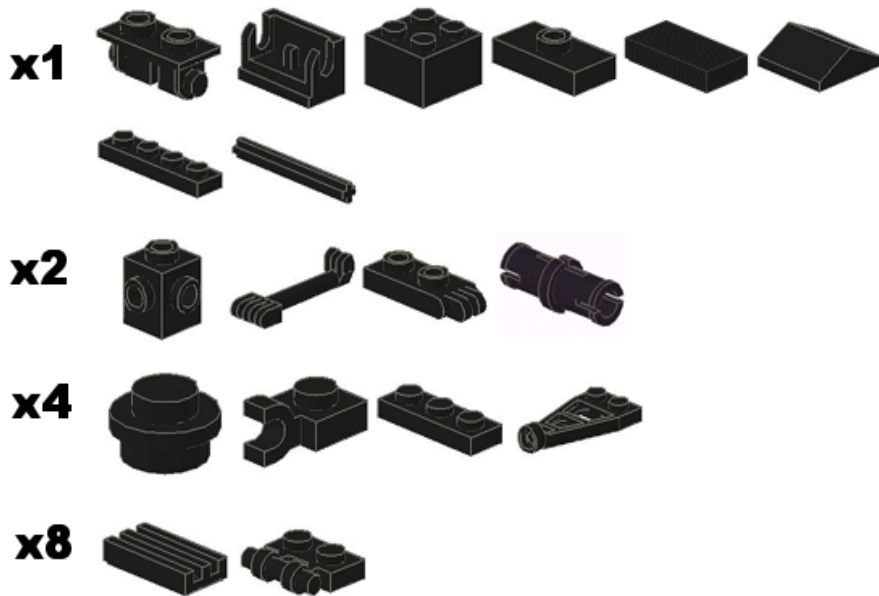

Light Blue-Grey Parts

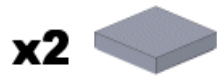

Other Parts

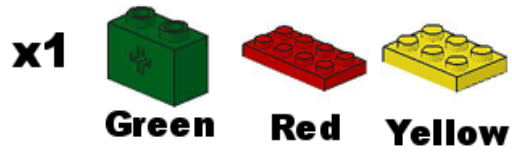

Quantity	Color	Part Number	Description
2	Black	4733.DAT	Brick 1 x 1 with Studs on Four Sides
1	Black	3003.DAT	Brick 2 x 2
1	Black	3937.DAT	Hinge 1 x 2 Base
1	Black	3938.DAT	Hinge 1 x 2 Top
			Hinge Bar 2 & 1/2 with 2 and 3 Fingers on Ends
2	Black	2880.DAT	
2	Black	4276.DAT	Hinge Plate 1 x 2 with 2 Fingers
4	Black	4073.DAT	Plate 1 x 1 Round
4	Black	6019.DAT	Plate 1 x 1 with Clip Horizontal
1	Black	3794.DAT	Plate 1 x 2 with 1 Stud
8	Black	2540.DAT	Plate 1 x 2 with Handle
4	Black	3623.DAT	Plate 1 x 3
1	Black	3710.DAT	Plate 1 x 4
1	Black	3300.DAT	Slope Brick 33 2 x 2 Double
4	Black	4596.DAT	Space Wing 4 x 2
1	Black	32073.DAT	Technic Axle 5
2	Black	2780.DAT	Technic Pin with Friction and Slots
8	Black	2412A.DAT	Tile 1 x 2 Grille without Groove
1	Black	3069B.DAT	Tile 1 x 2 with Groove
2	Dark-Gray	3005.DAT	Brick 1 x 1
1	Dark-Gray	6222.DAT	Brick 4 x 4 Round with Holes
1	Dark-Gray	4740.DAT	Dish 2 x 2 Inverted
2	Dark-Gray	4073.DAT	Plate 1 x 1 Round
2	Dark-Gray	3794.DAT	Plate 1 x 2 with 1 Stud
1	Dark Blue-Grey	3839B.DAT	Plate 1 x 2 with Handles Type 2
2	Dark-Gray	3022.DAT	Plate 2 x 2
2	Dark-Gray	3021.DAT	Plate 2 x 3
2	Dark-Gray	3958.DAT	Plate 6 x 6
1	Dark-Gray	2412B.DAT	Tile 1 x 2 Grille with Groove
2	Dark-Gray	2432.DAT	Tile 1 x 2 with Handle
2	Dark-Gray	30155.DAT	Wheel Centre Spoked Small
1	Dark-Gray	43719.dat	Wing 4 x 4 with 2 x 2 Cutout
1	Green	32064.DAT	Technic Brick 1 x 2 with Axlehole
2	Light Blue-Grey	3068B.DAT	Tile 2 x 2 with Groove
1	Light-Gray	43898s01.dat	~Dish 3 x 3 (Not right part file)
2	Light-Gray	3659.DAT	Arch 1 x 4
2	Light-Gray	2436.DAT	Bracket 1 x 2 - 1 x 4
2	Light-Gray	44728.DAT	Bracket 1 x 2 - 2 x 2
6	Light-Gray	4070.DAT	Brick 1 x 1 with Headlight
4	Light Blue -Grey	47905.DAT	Brick 1 x 1 with Studs on Two Opposite Sides
5	Light-Gray	3004.DAT	Brick 1 x 2
1	Light-Gray	3010.DAT	Brick 1 x 4
4	Light-Gray	6091.DAT	Brick 2 x 1 x 1 & 1/3 with Curved Top
2	Light-Gray	2357.DAT	Brick 2 x 2 Corner
1	Light-Gray	6222.DAT	Brick 4 x 4 Round with Holes
2	Light-Gray	30360.DAT	Cylinder 3 x 6 x 2 2/3 Horizontal

1	Light-Gray	3960.DAT	Dish 4 x 4 Inverted
1	Light-Gray	3024.DAT	Plate 1 x 1
9	Light-Gray	4073.DAT	Plate 1 x 1 Round
6	Light-Gray	3023.DAT	Plate 1 x 2
3	Light-Gray	3794.DAT	Plate 1 x 2 with 1 Stud
4	Light-Gray	2540.DAT	Plate 1 x 2 with Handle
7	Light-Gray	3623.DAT	Plate 1 x 3
1	Light-Gray	3666.DAT	Plate 1 x 6
2	Light-Gray	3022.DAT	Plate 2 x 2
1	Light-Gray	3021.DAT	Plate 2 x 3
3	Light-Gray	3020.DAT	Plate 2 x 4
1	Light-Gray	3795.DAT	Plate 2 x 6
1	Light-Gray	30363.DAT	Slope Brick 18 4 x 2
2	Light-Gray	4286.DAT	Slope Brick 33 3 x 1
2	Light-Gray	3665.DAT	Slope Brick 45 2 x 1 Inverted
2	Light-Gray	3039.DAT	Slope Brick 45 2 x 2
2	Light-Gray	3700.DAT	Technic Brick 1 x 2 with Hole
4	Light-Gray	32000.DAT	Technic Brick 1 x 2 with Holes
4	Light-Gray	4274.DAT	Technic Pin 1/2
2	Light-Gray	2555.DAT	Tile 1 x 1 with Clip
8	Light-Gray	2412B.DAT	Tile 1 x 2 Grille with Groove
1	Light-Gray	3069B.DAT	Tile 1 x 2 with Groove
6	Light-Gray	2431.DAT	Tile 1 x 4
2	Light-Gray	4162.DAT	Tile 1 x 8
4	Light-Gray	3068B.DAT	Tile 2 x 2 with Groove
1	Light-Gray	2512.DAT	Tipper Bucket Small
1	Light-Gray	4855.DAT	Wedge 4 x 4 Triple Inverted
2	Light-Gray	6153.DAT	Wedge 6 x 4
1	Light-Gray	4856.DAT	Wedge 6 x 4 Inverted
1	Red	3020.DAT	Plate 2 x 4
2	Trans-Black	3069B.DAT	Tile 1 x 2 with Groove
2	Trans-Blue	3069B.DAT	Tile 1 x 2 with Groove
8	Trans-Light-Green	3062B.DAT	Brick 1 x 1 Round with Hollow Stud
5	Green	3941.DAT	Brick 2 x 2 Round
2	White	4740.DAT	Dish 2 x 2 Inverted
2	White	3794.DAT	Plate 1 x 2 with 1 Stud
2	Yellow	3003.DAT	Brick 2 x 2
2	Yellow	4073.DAT	Plate 1 x 1 Round
1	Yellow	3021.DAT	Plate 2 x 3

Building Instructions

Now comes the fun part – actually building the Snack-Sized Serenity Model.

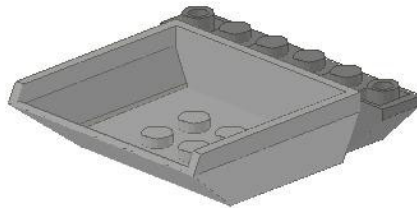
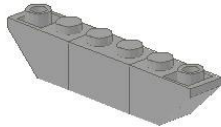

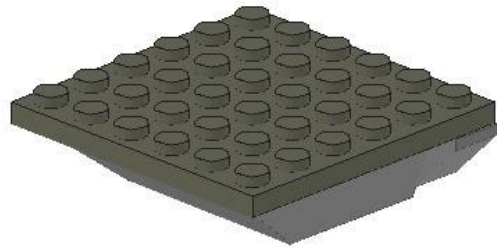
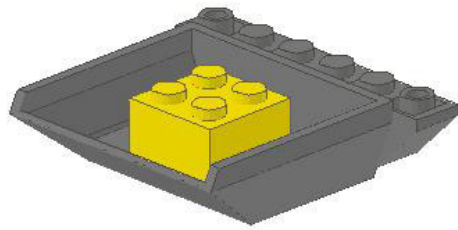

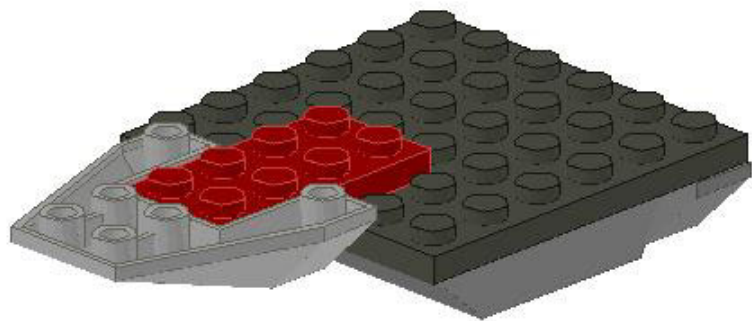
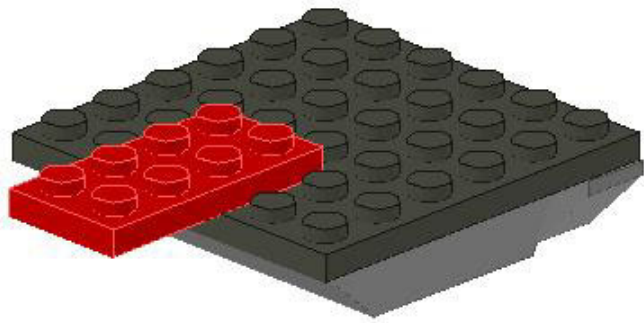

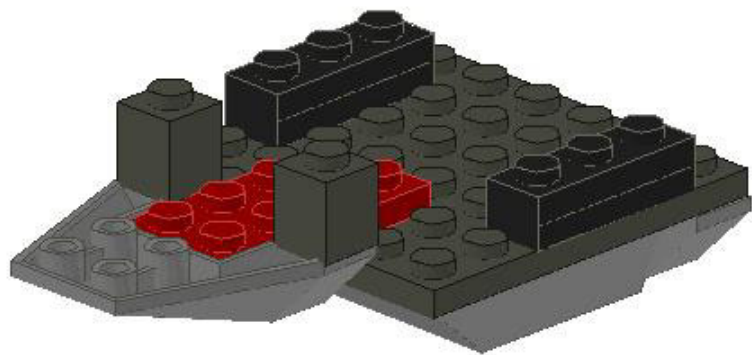
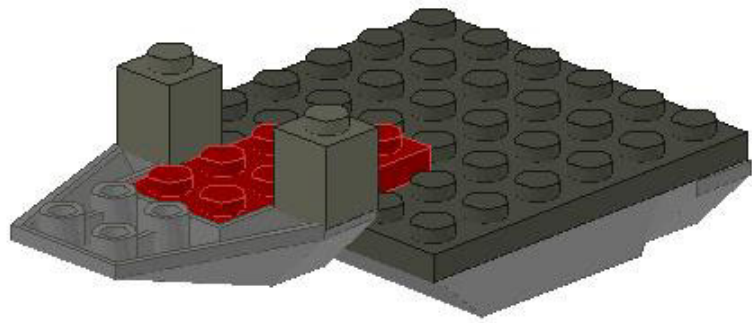

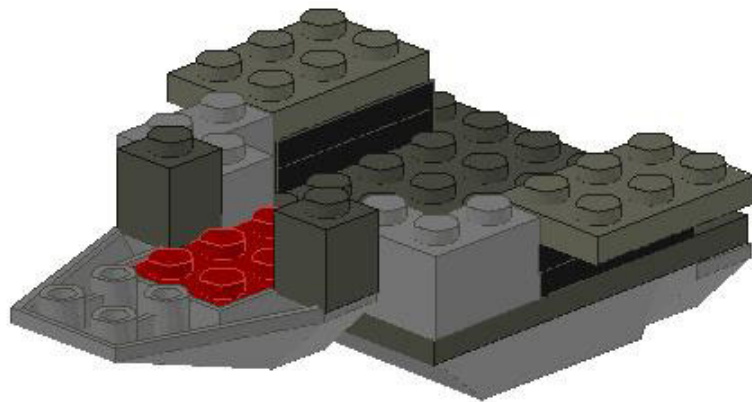
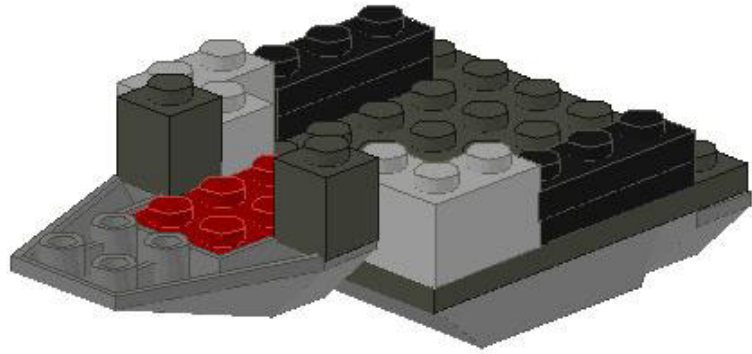

The wings on Snack-Size are a little tricky, so I recommend building these sub-assemblies first. You'll need two of each, one for each side. This first one is pretty straight-forward.

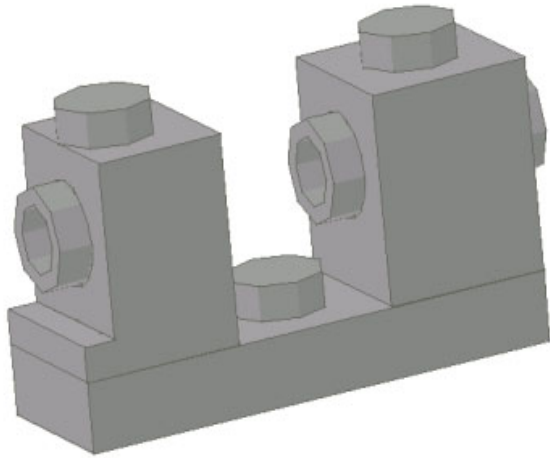

The second combines these four bits

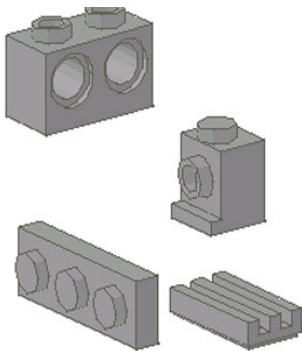

into this:

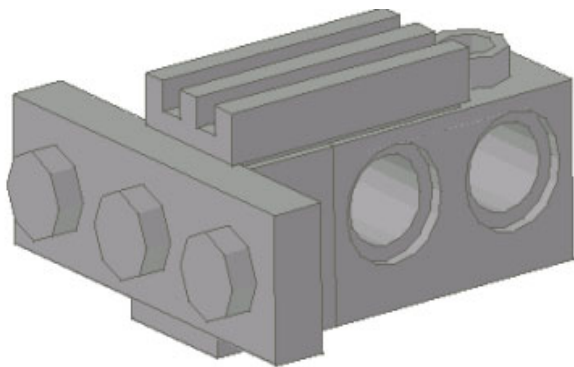

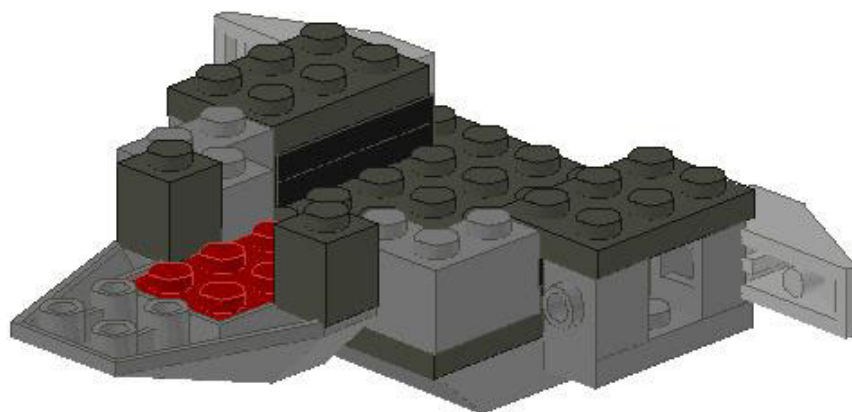
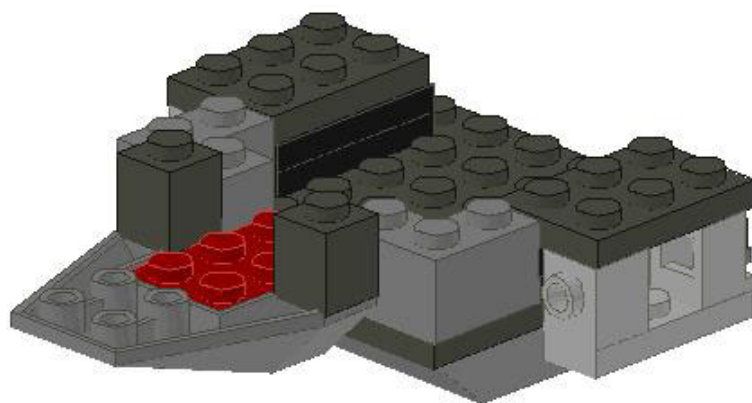

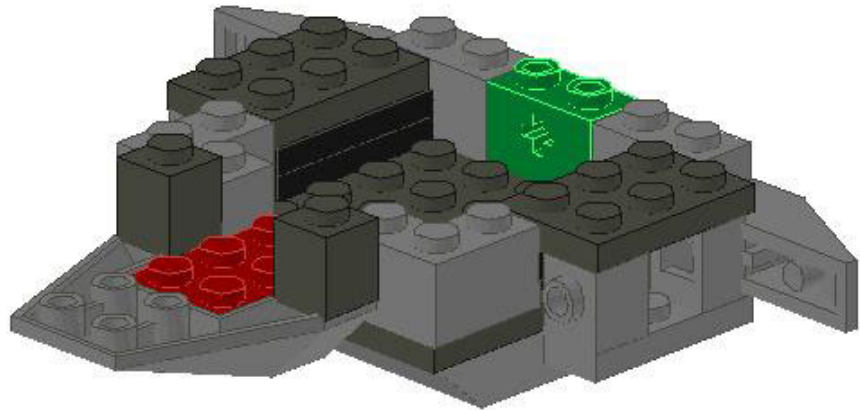
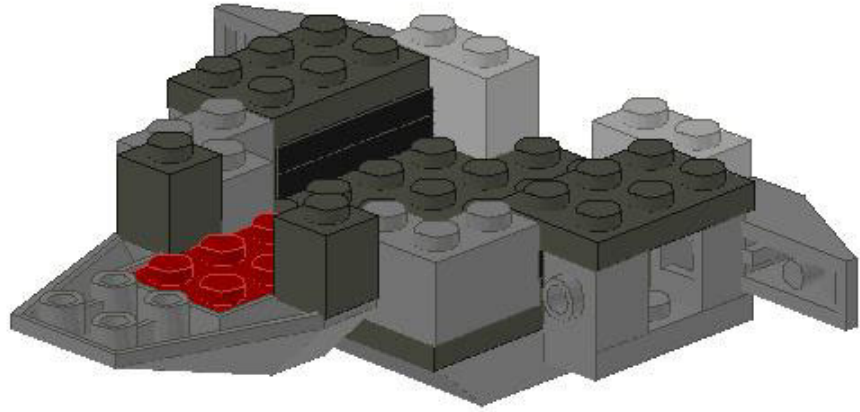

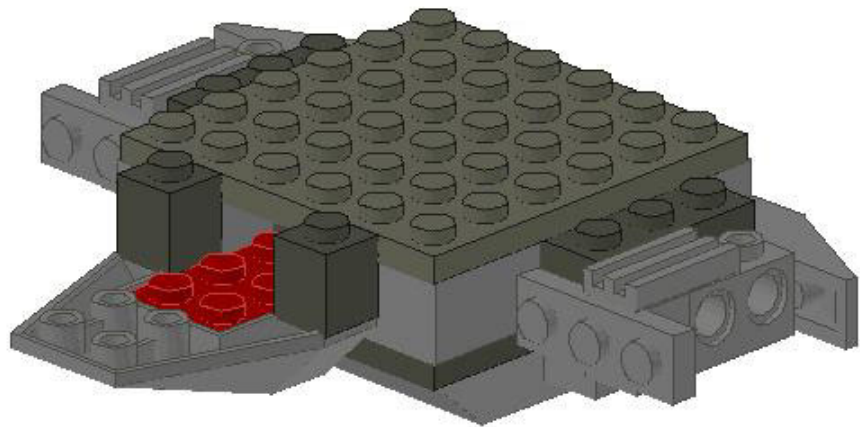
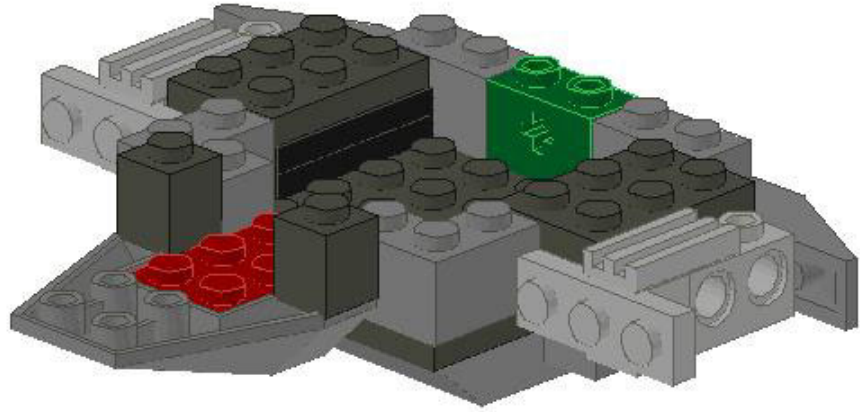

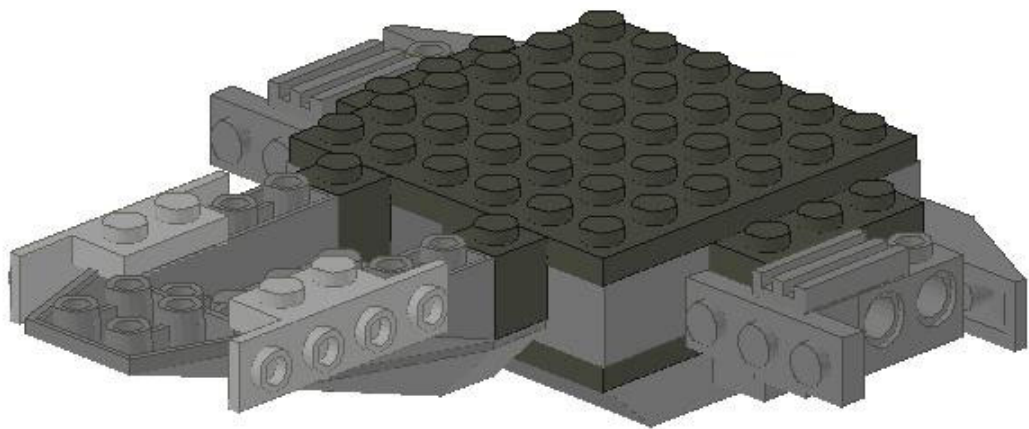
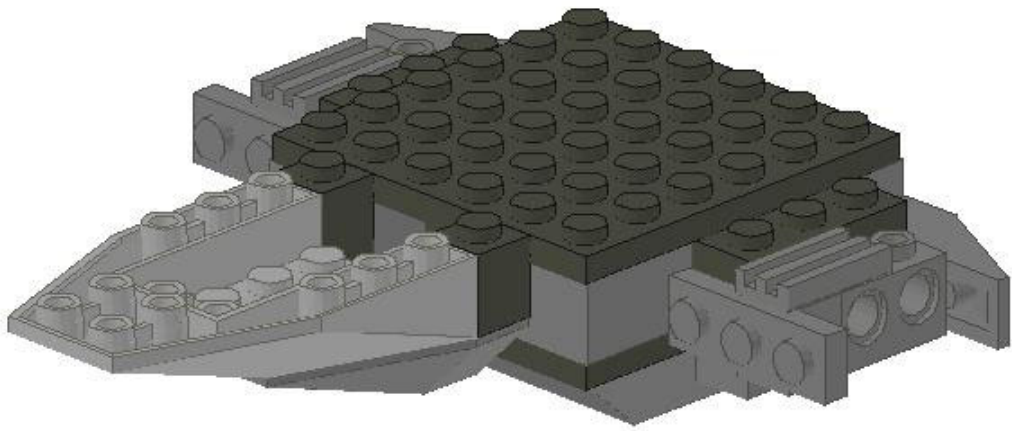

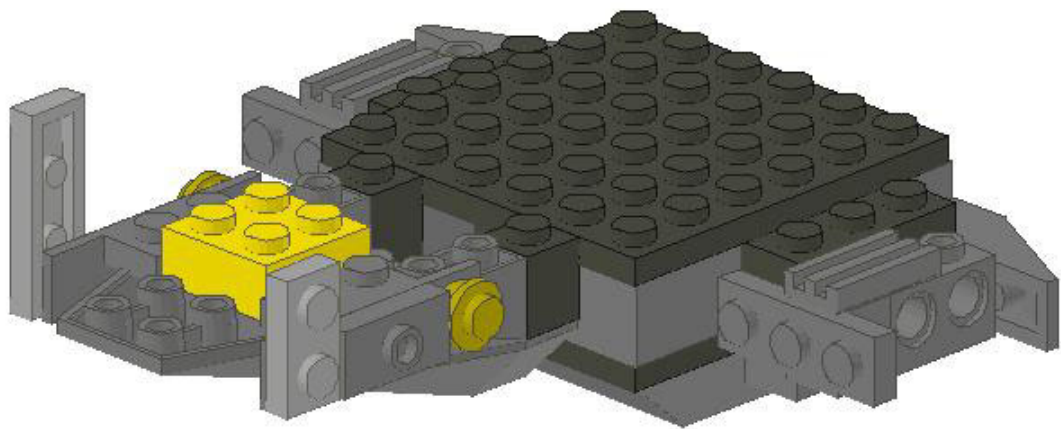
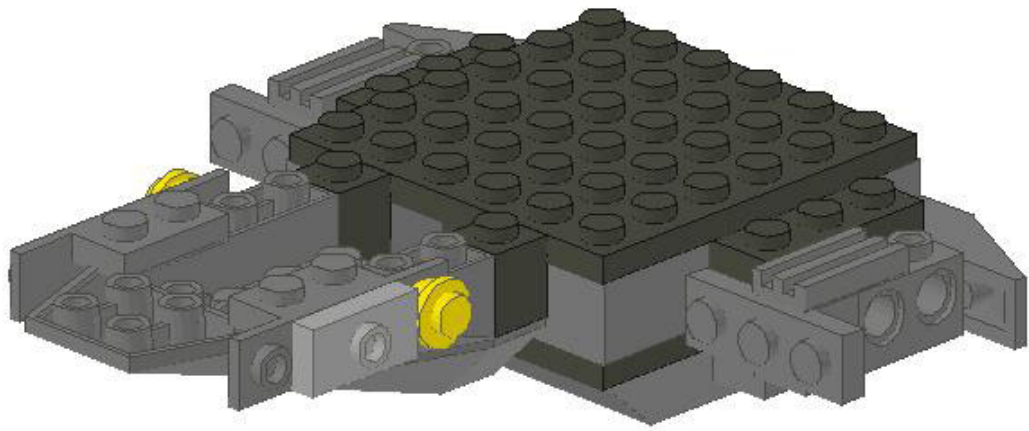

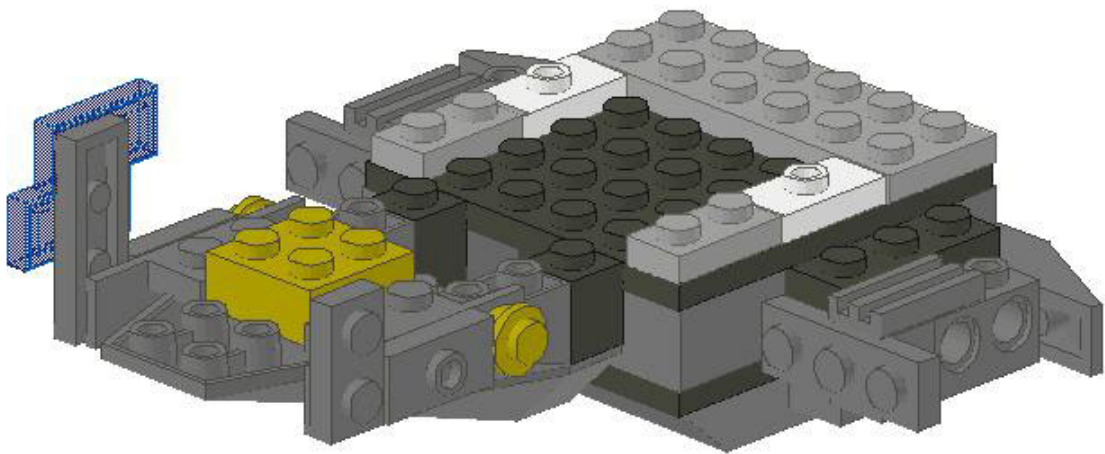
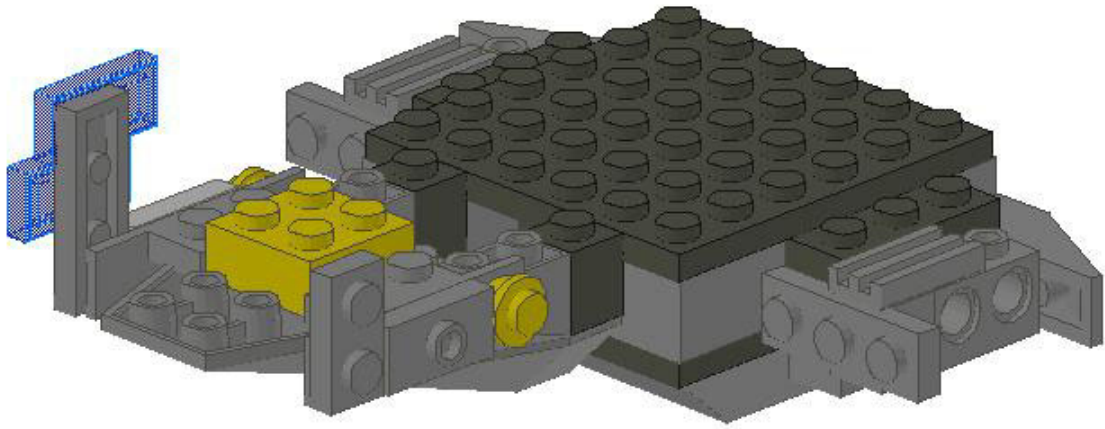

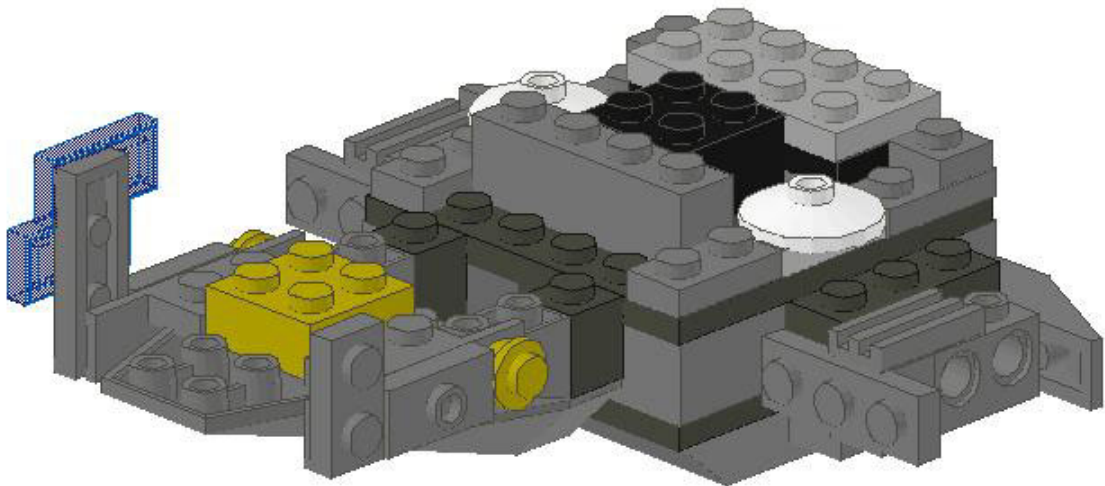
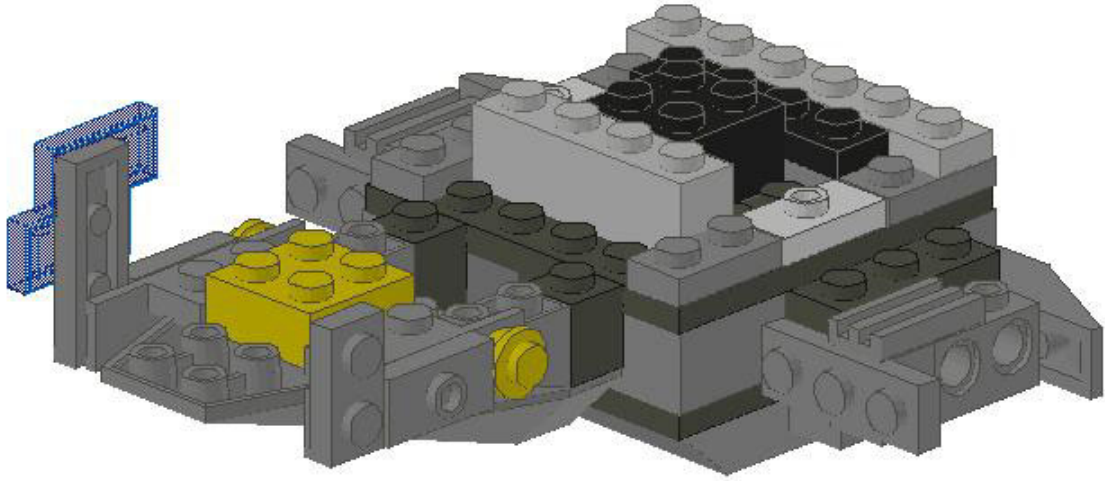

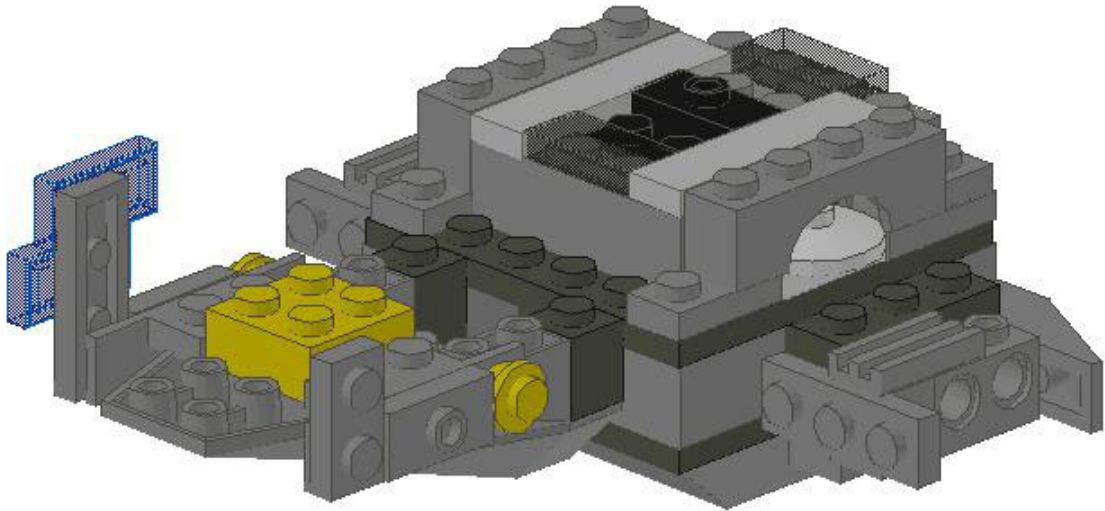
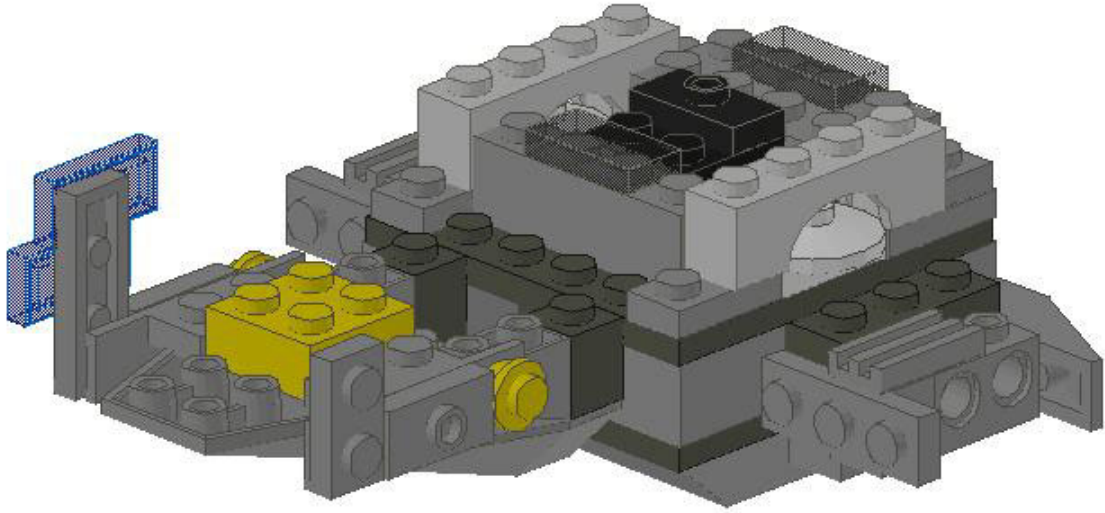

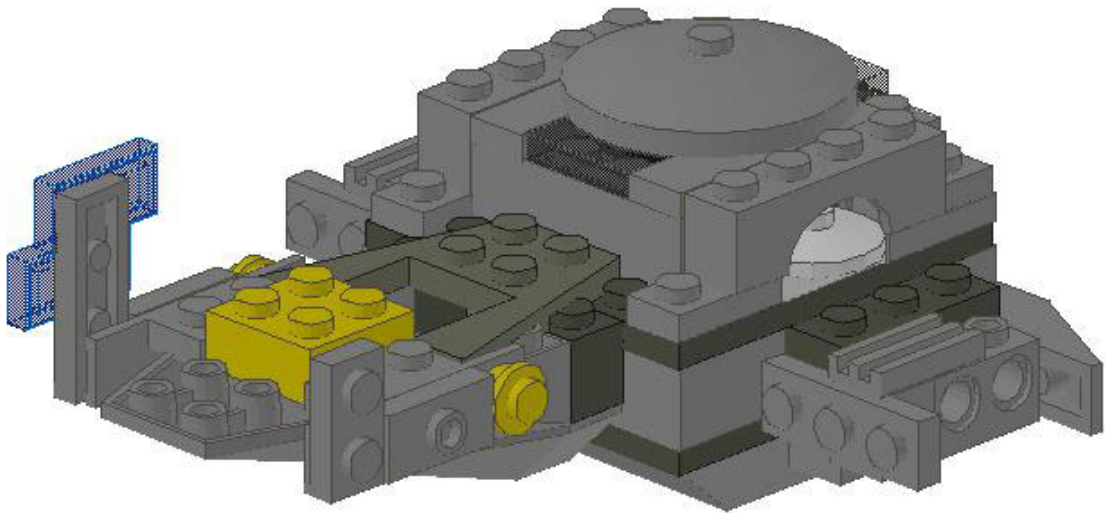
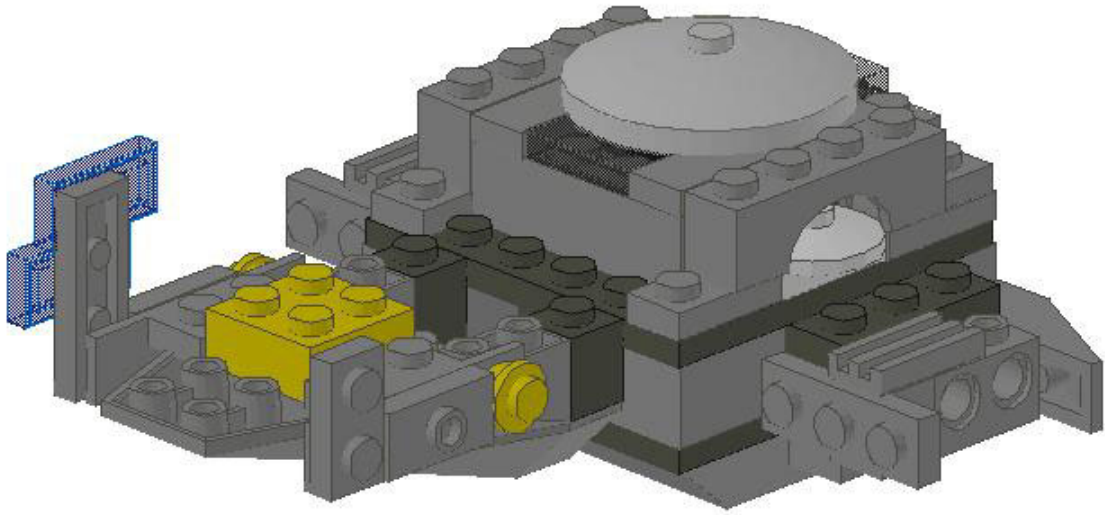

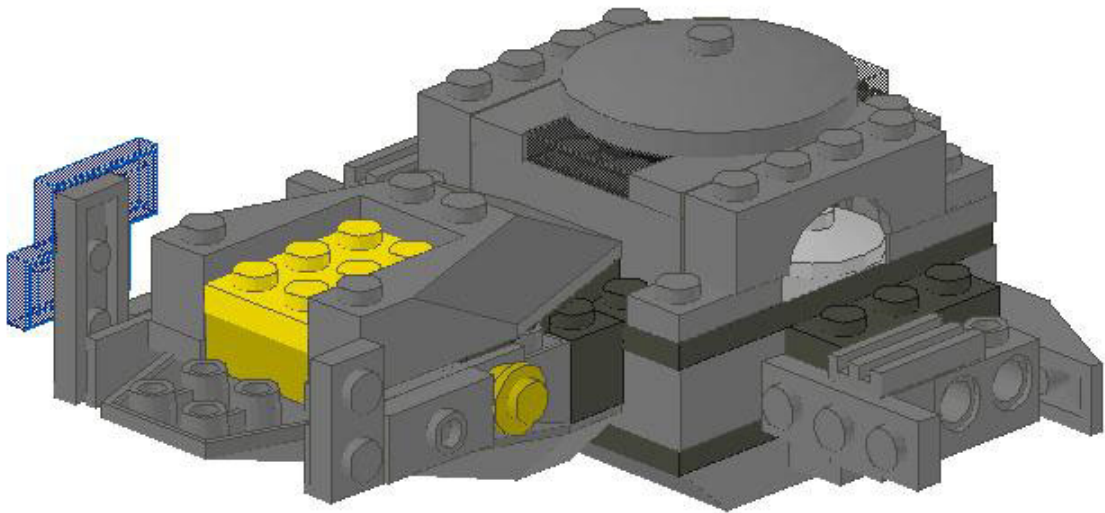
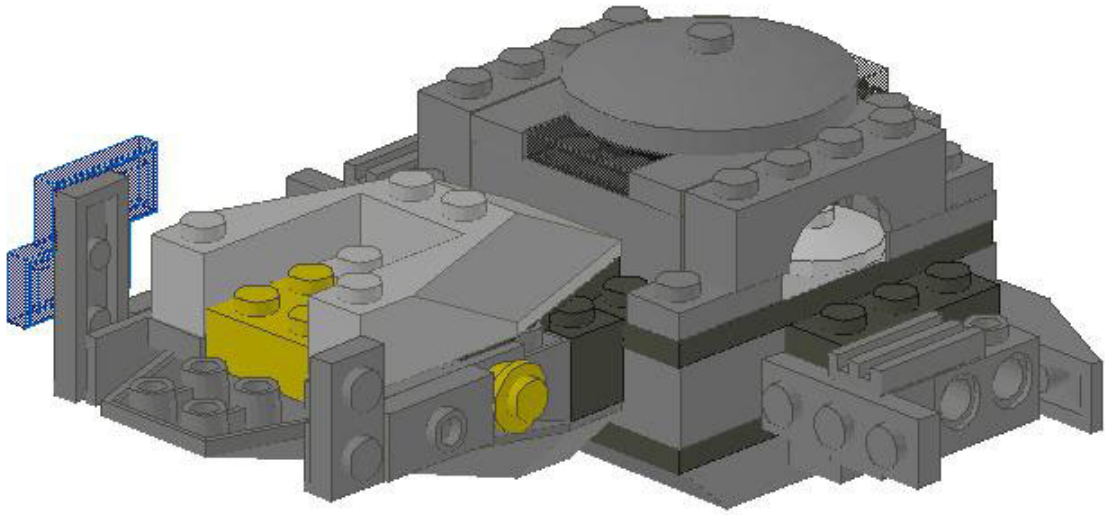

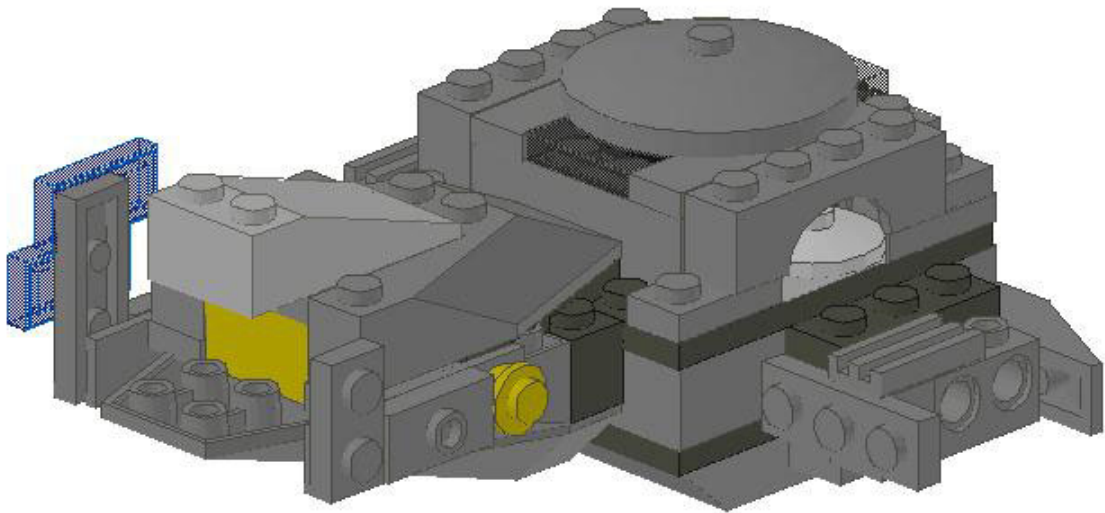
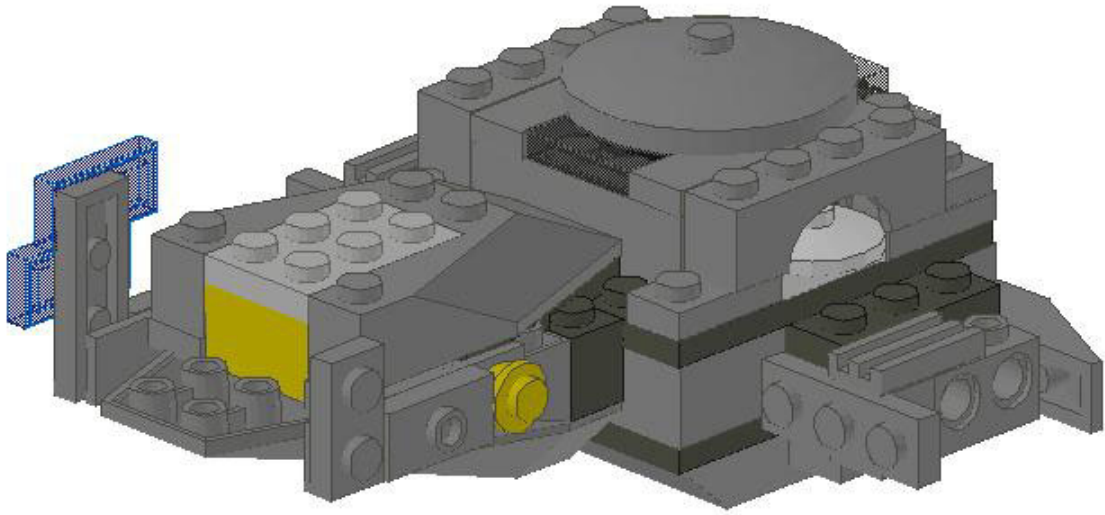

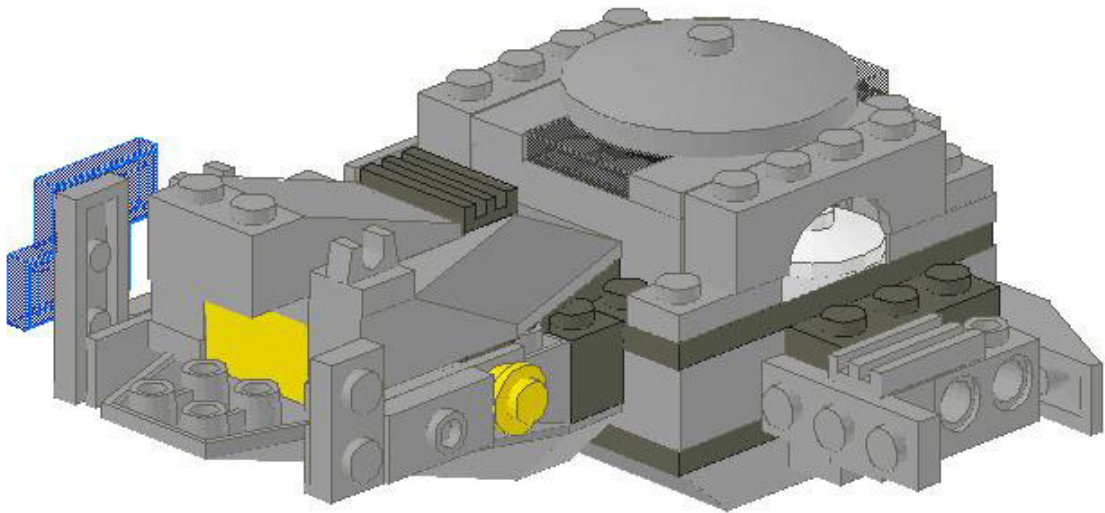
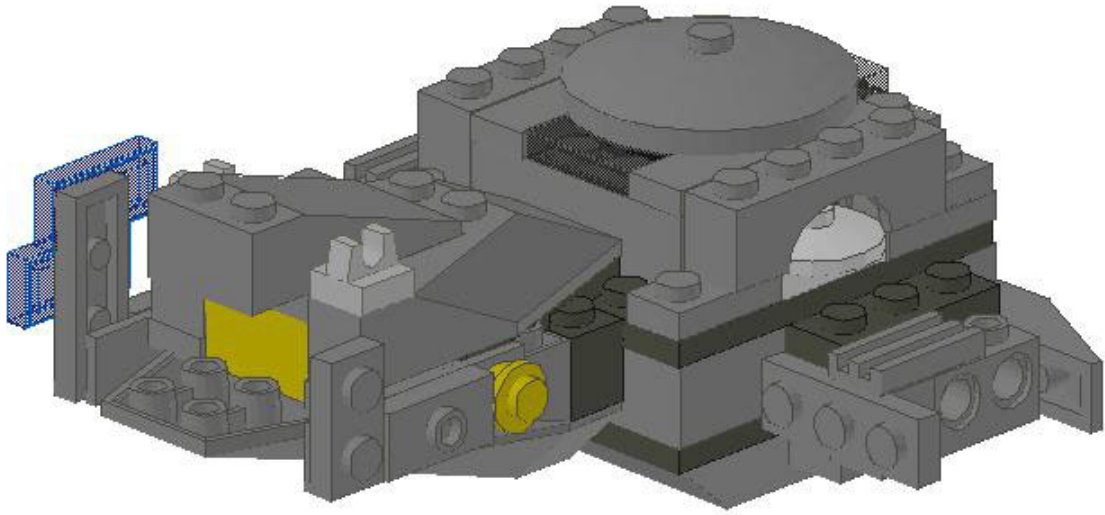

That completes the main hull of Snack-Size, now we'll build the bridge area.

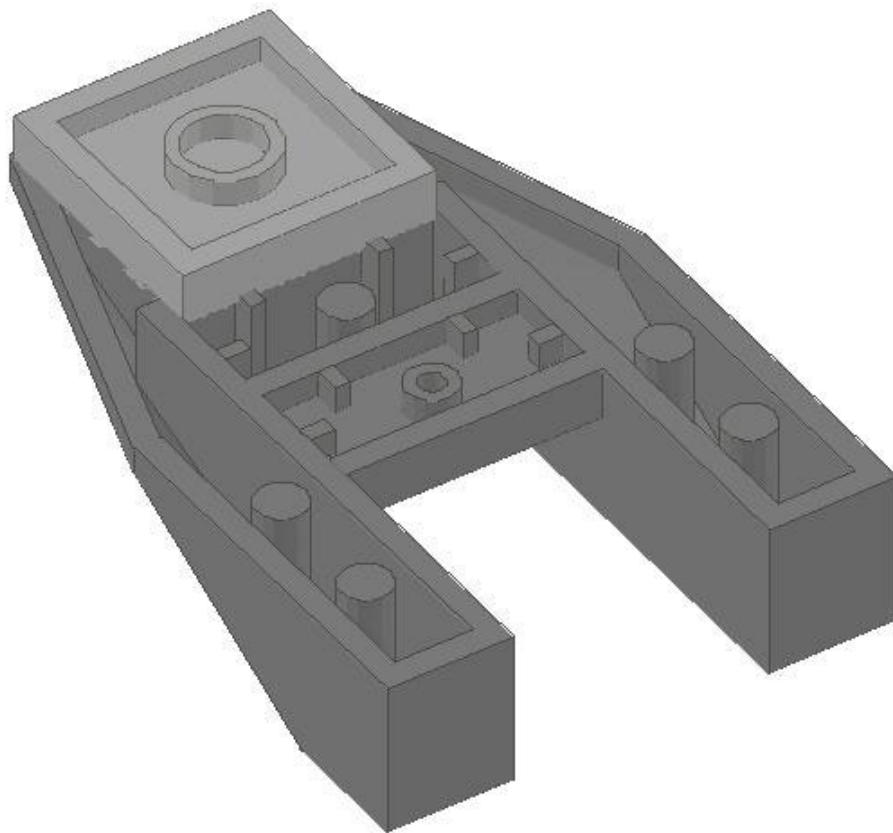
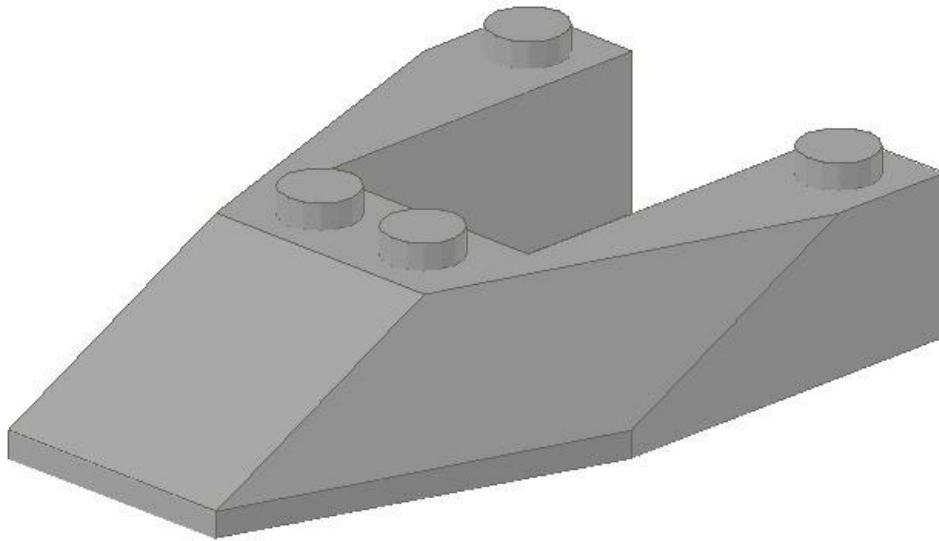

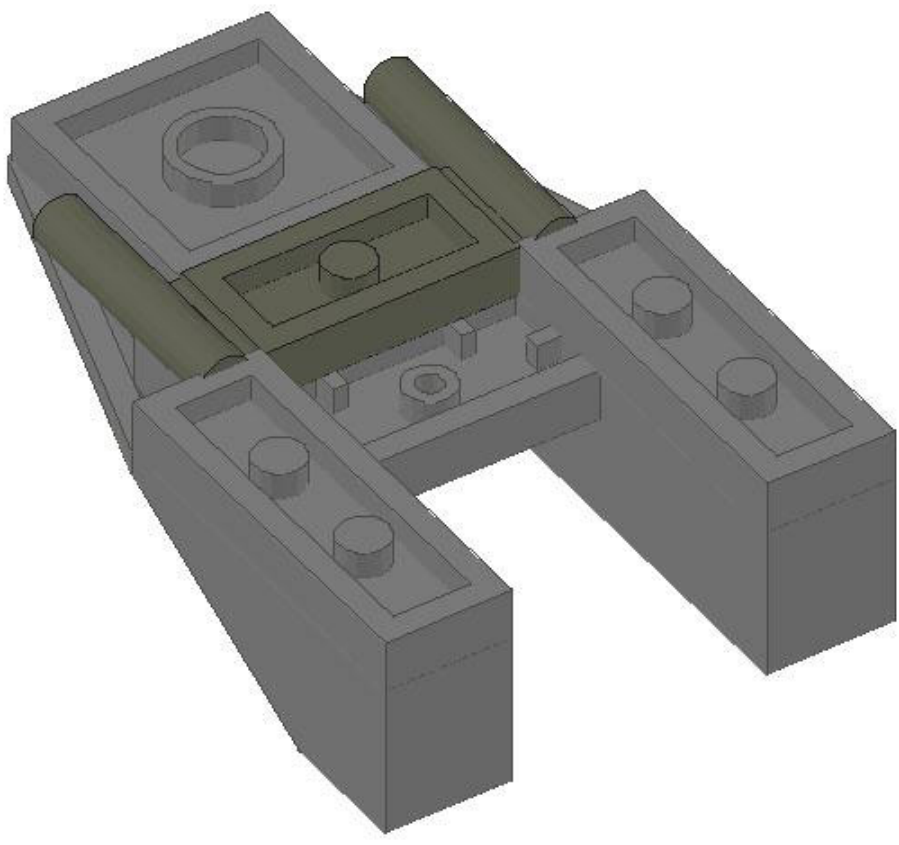
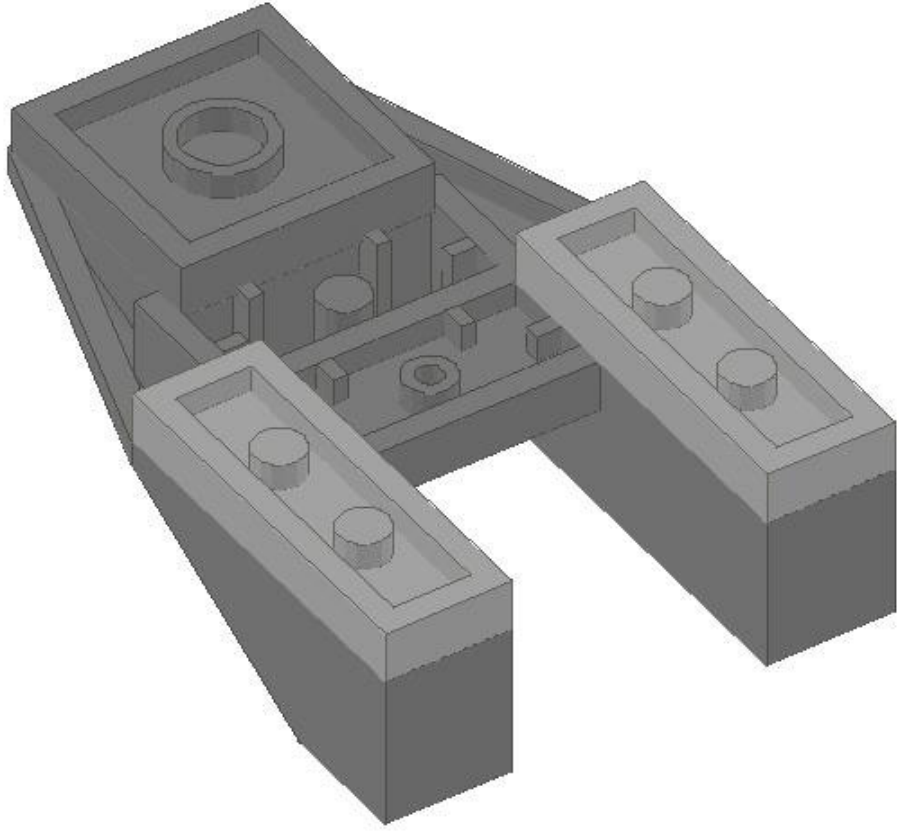

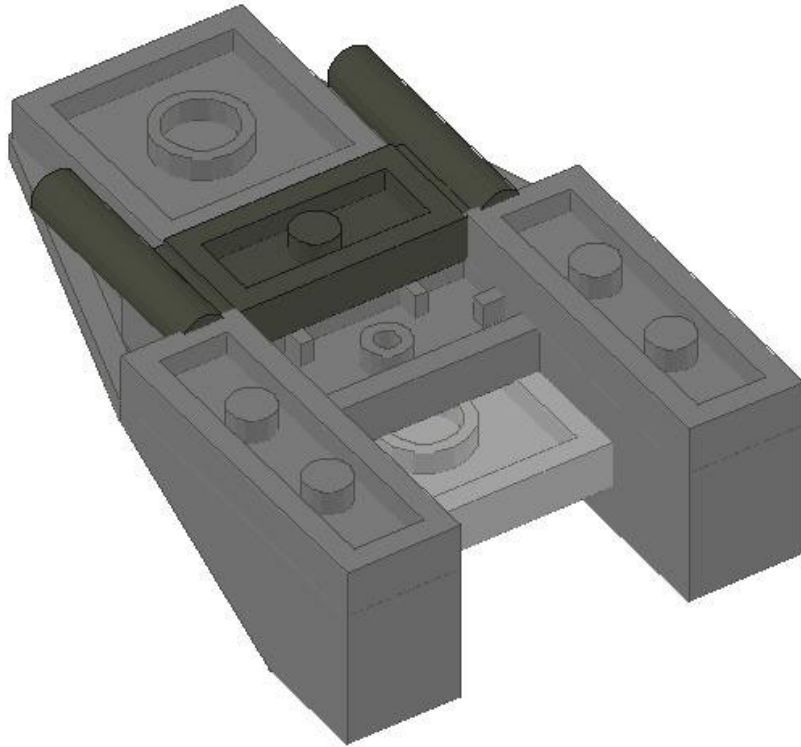

This next step attaches the black hinge piece. If you haven't already assembled the two halves, do so now... Also note the orientation – if you put this bit in backwards the nose won't bend down correctly.

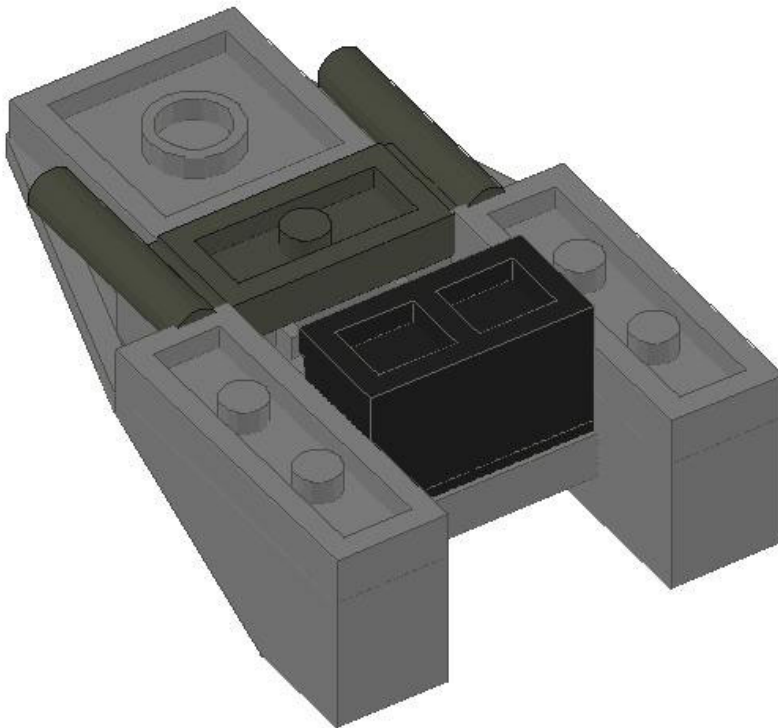

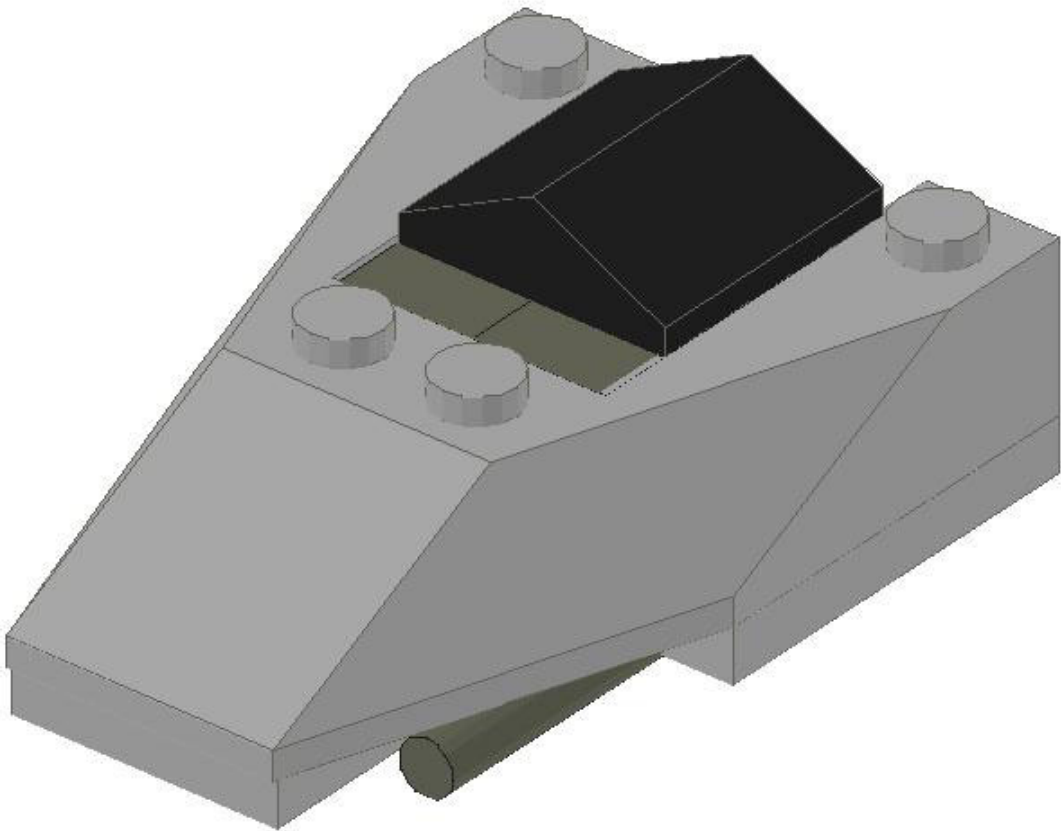
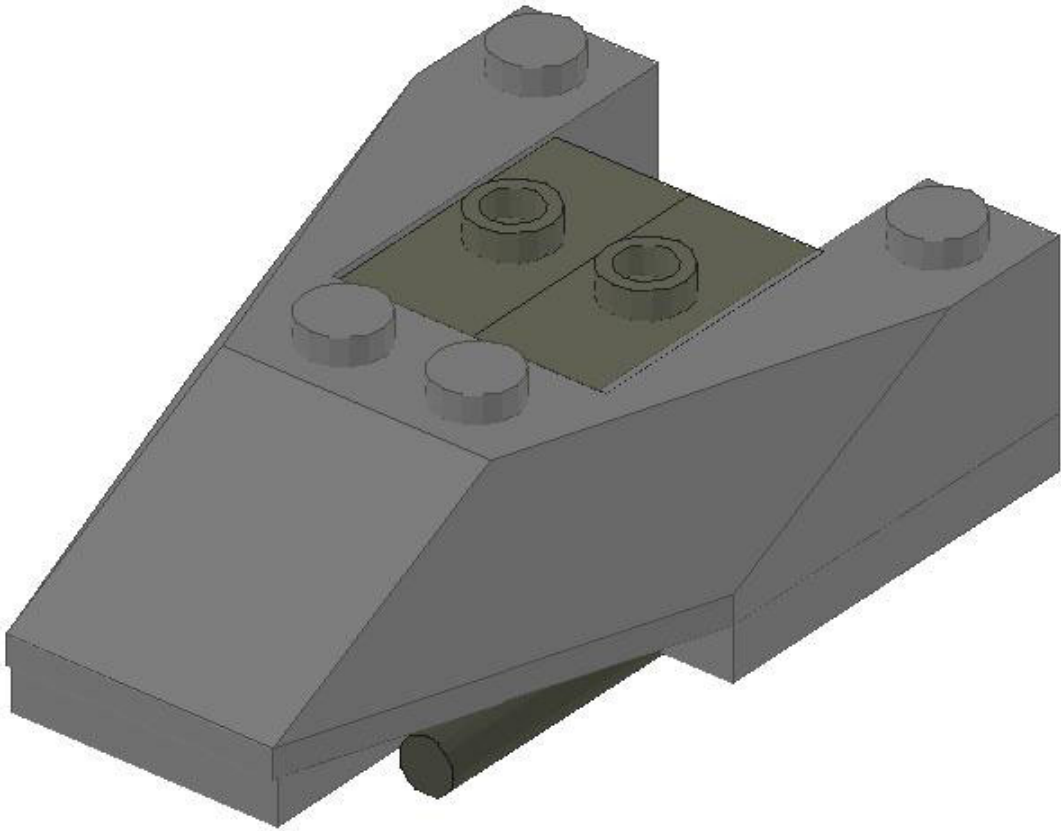

You can now connect the bridge and the hull together, like so:

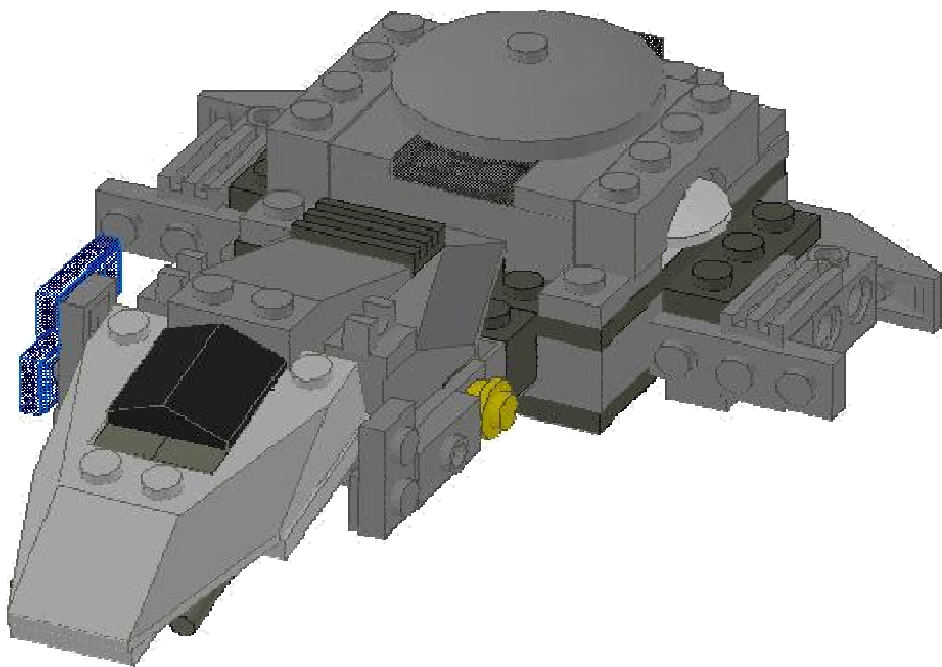

Next, we'll be building the "light ring" and landing support section.

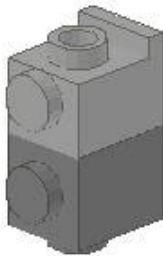
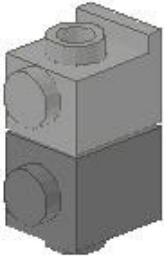
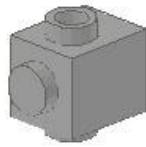
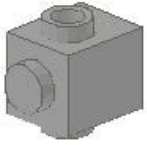

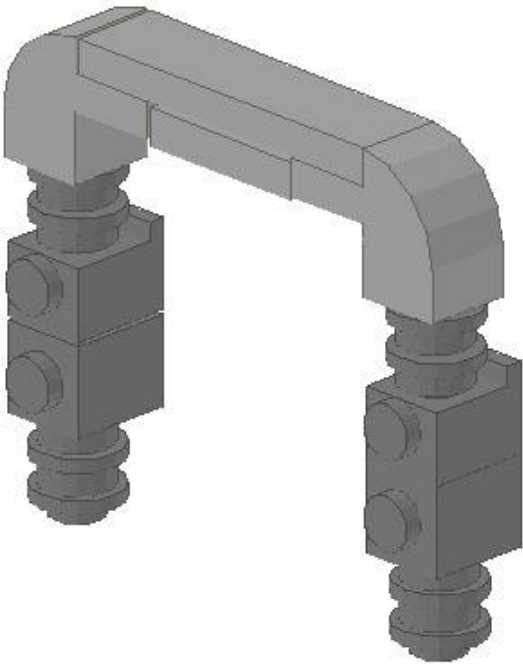
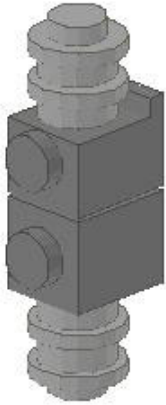

These are the “Light Blue-Grey” tiles – not the light grey.

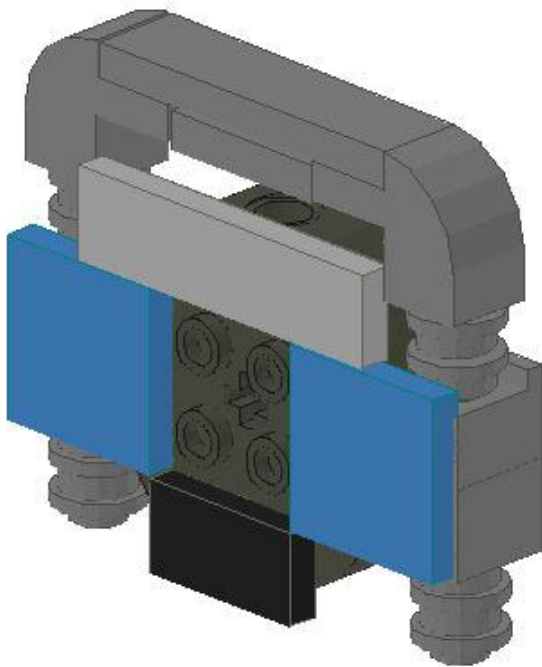
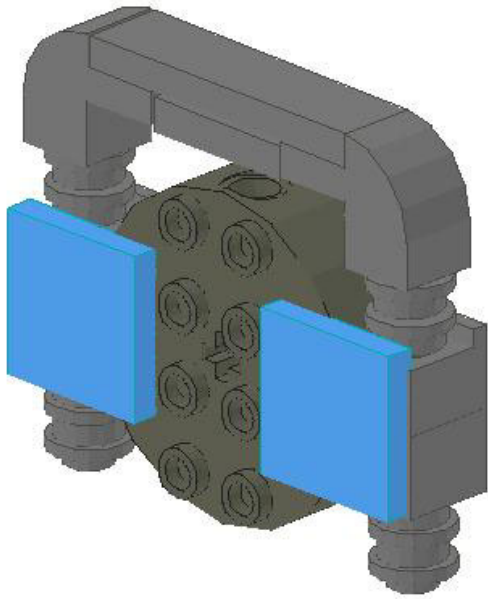

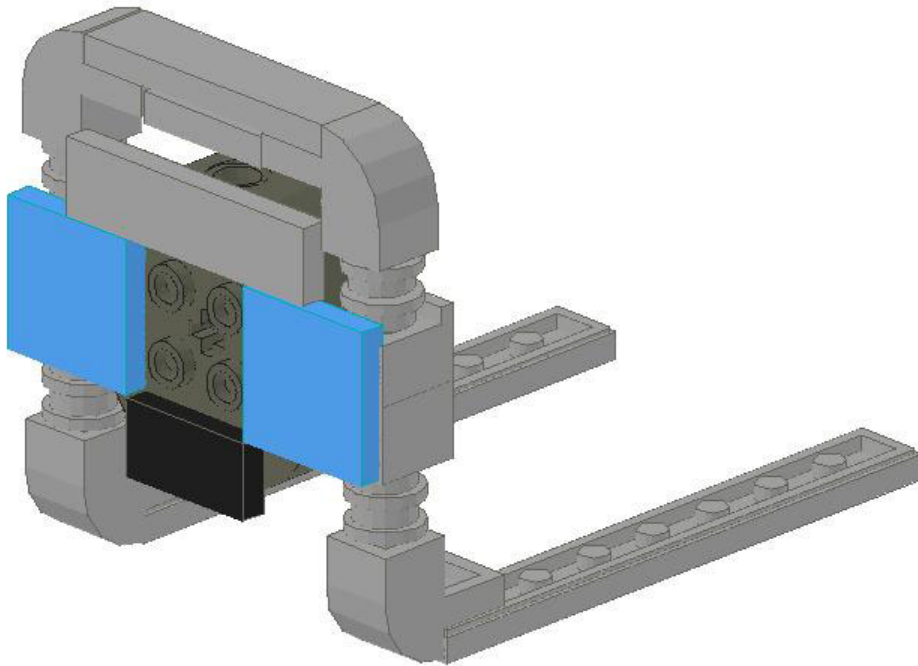
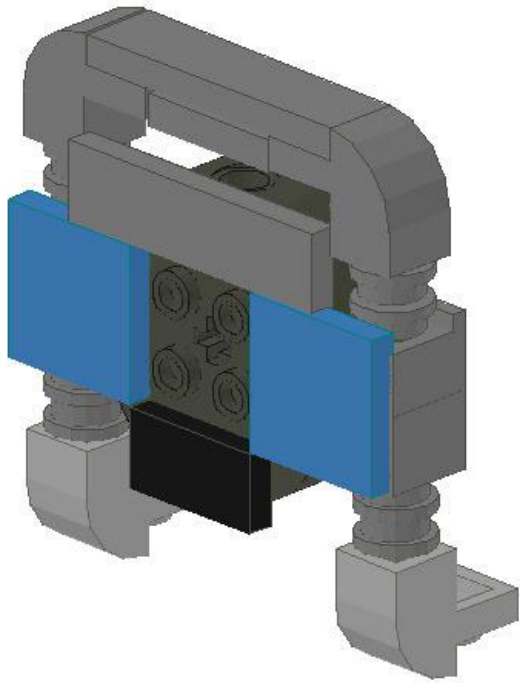

That completes another little section of the model. It won't connect to Serenity's hull until we build the firefly drive, though.

Next up: The Firefly Drive

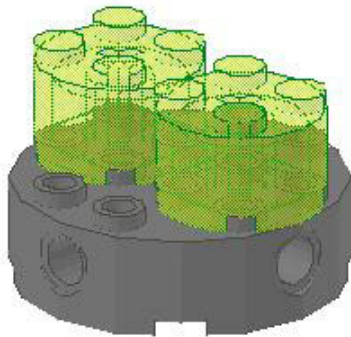
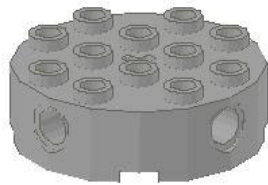

Four clear 1x1 round bricks join the two 2x2s

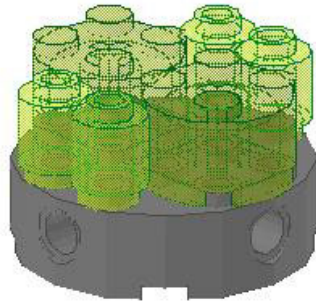

Then two more 2x2s go on top of that.

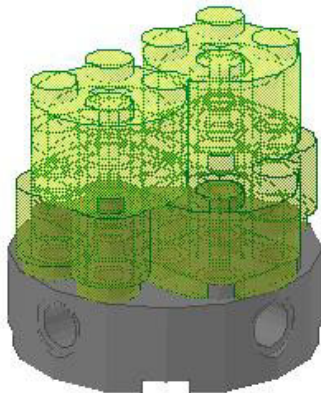

Then four more 1x1 bricks...

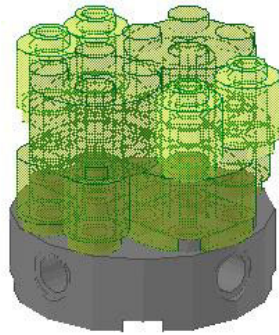

Then one last 2x2 Brick on top.

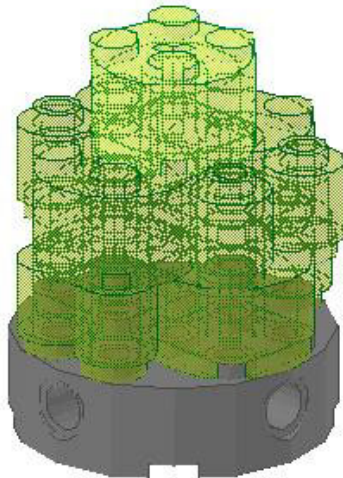

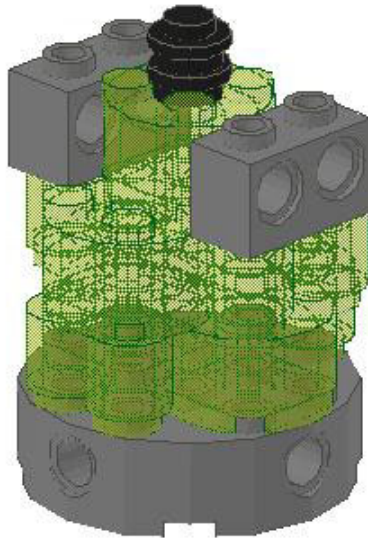
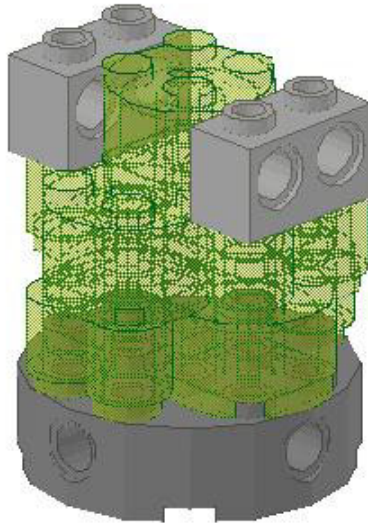

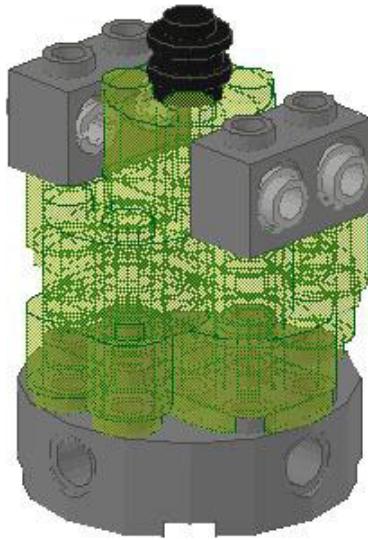

Note that the 1x1 round dots go on both sides in this step.

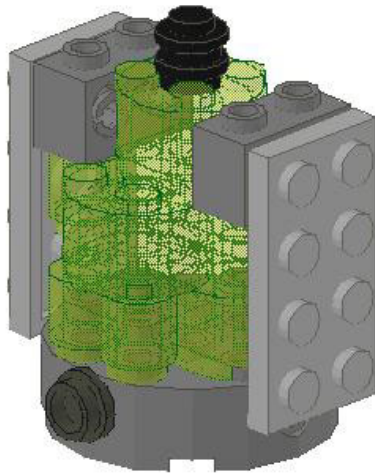

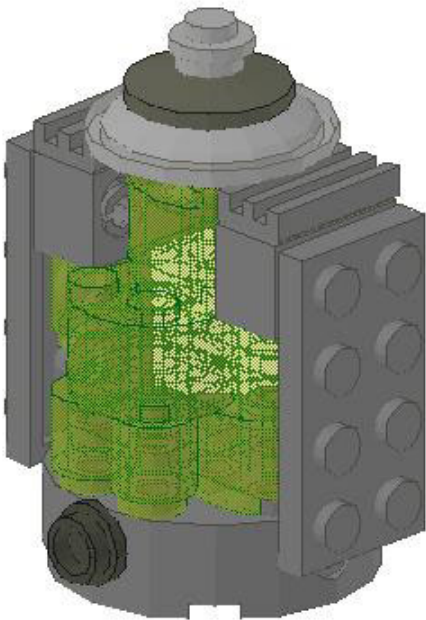
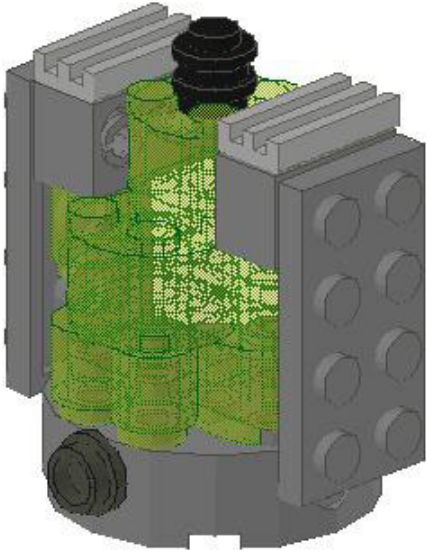

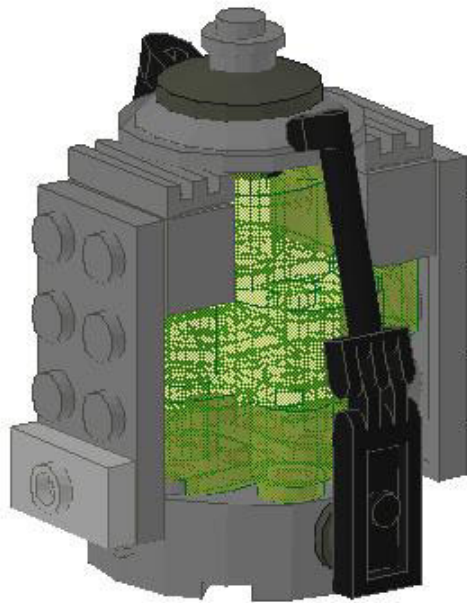
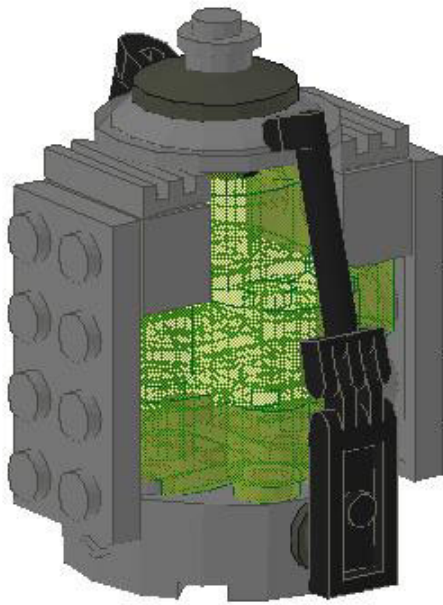

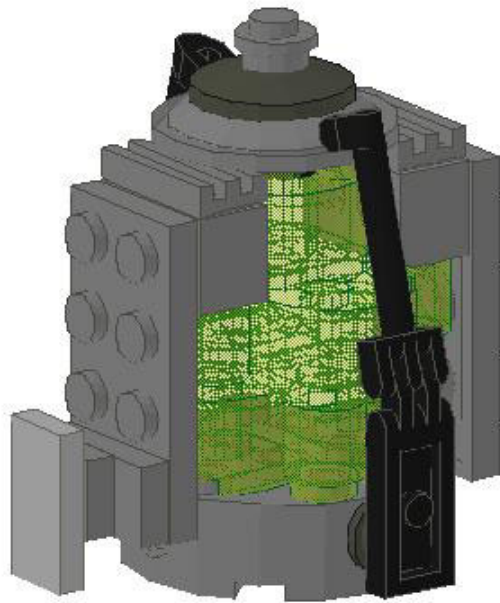
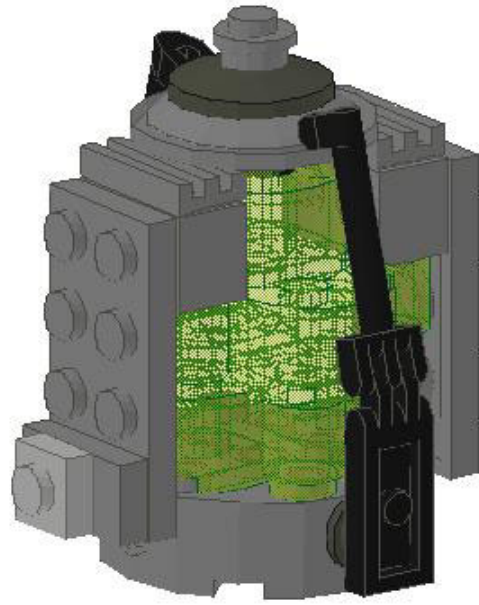

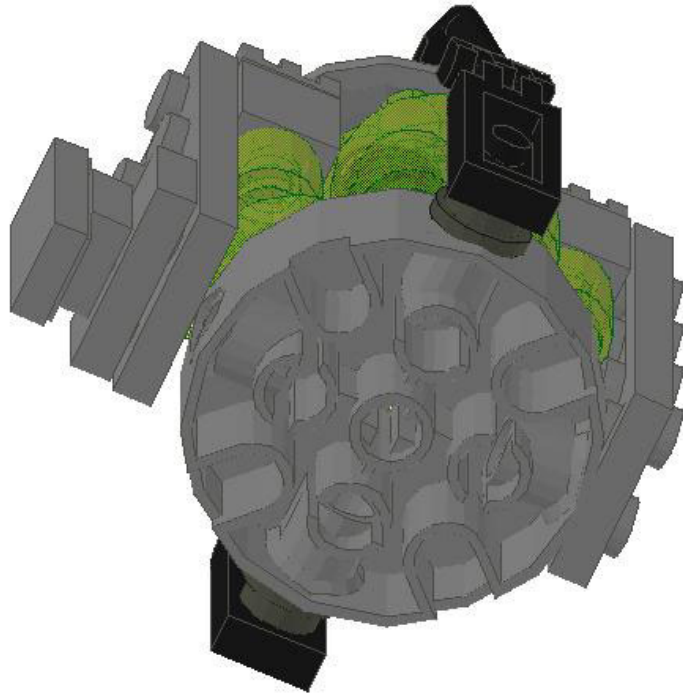

This next step is a bit tricky – the clips probably won't stay on their own. The next step locks them into place, though.

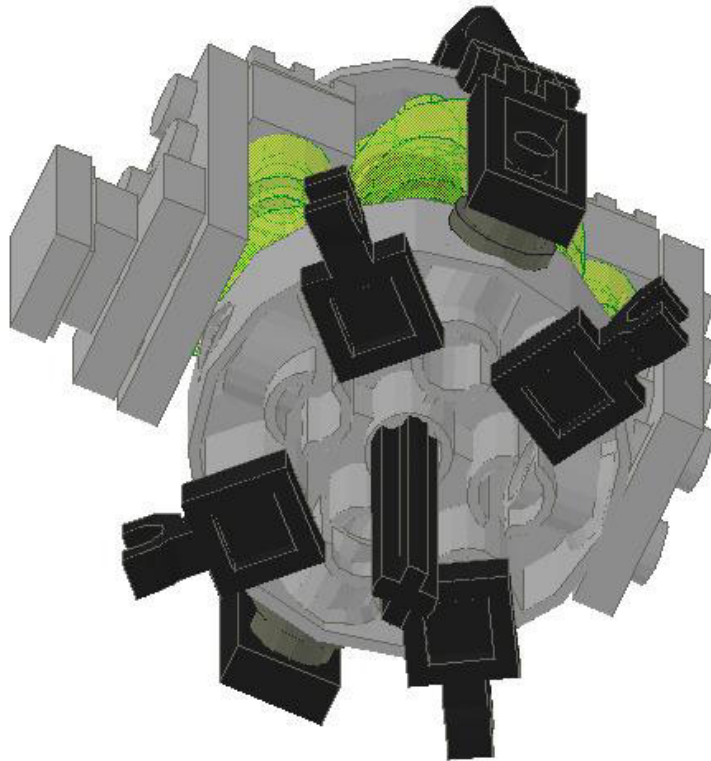

You should now be able to connect the main segments of Serenity together like this:

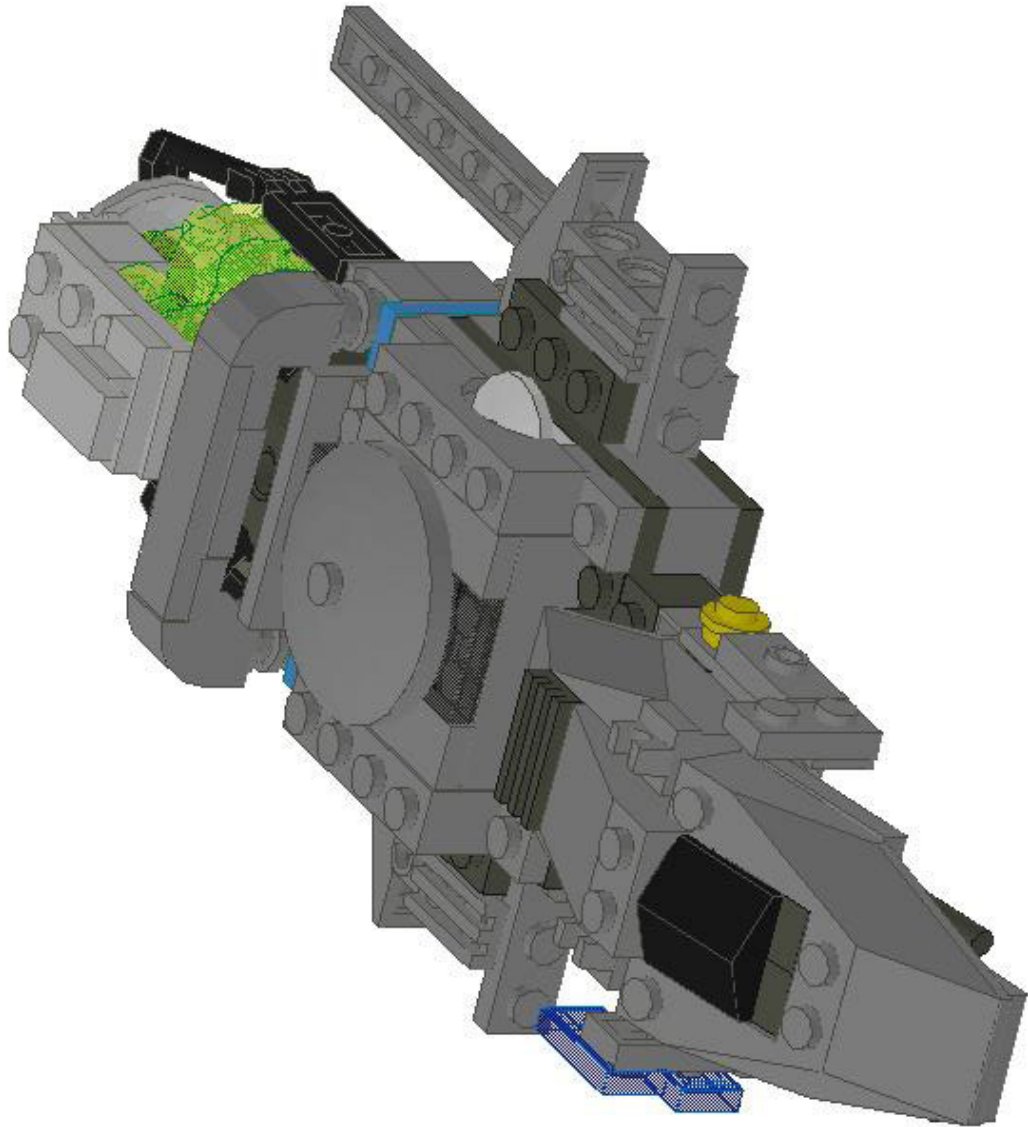

Next, you'll need to build four of these:

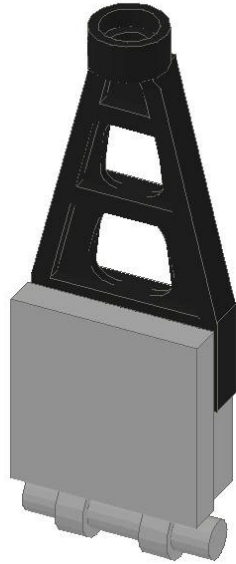

They clip onto the drive section like this. Careful! This step is pretty delicate – you might need to add these on before you group everything together.

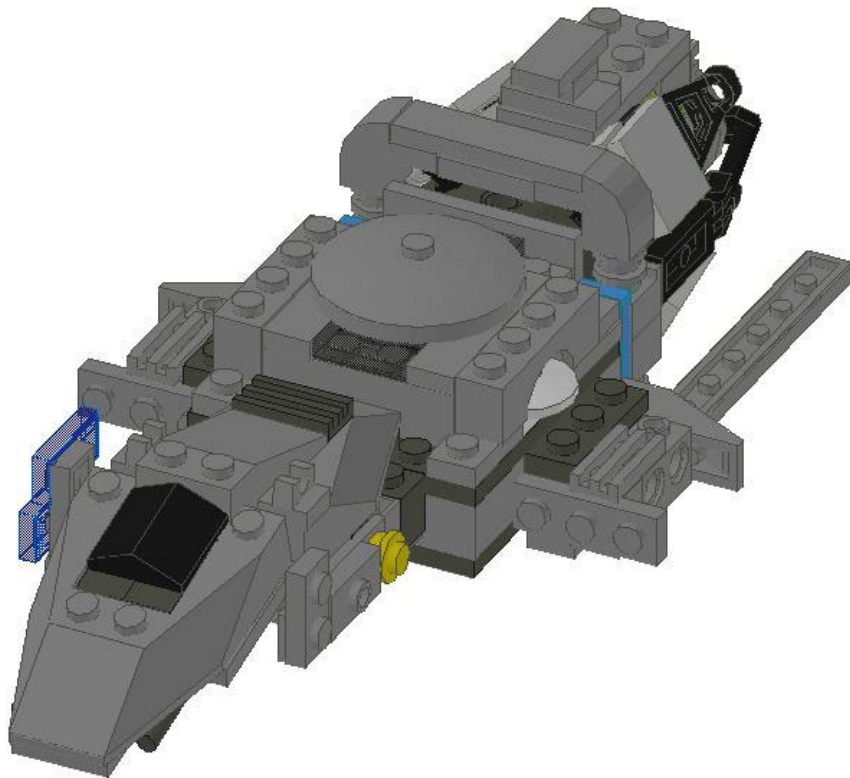

Next up, the engine mounts. You'll be building two of these:

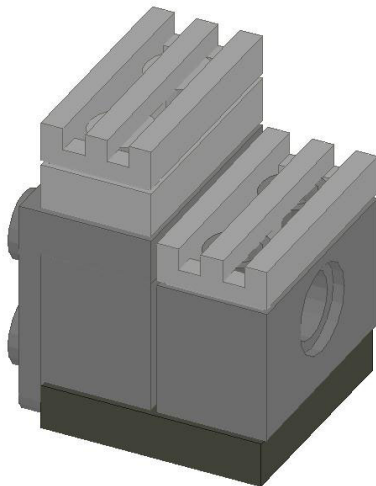
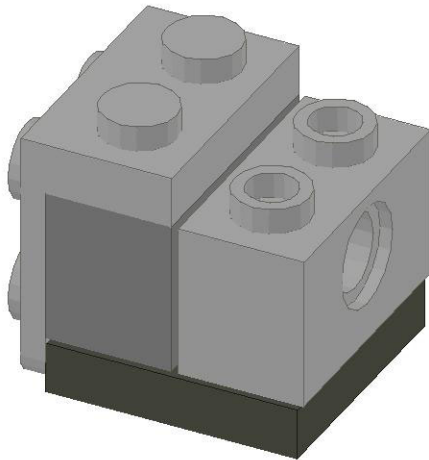
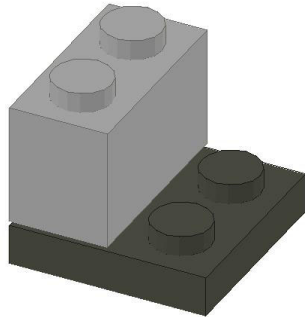

You're adding both a 1x2 plate and a grill in this step.

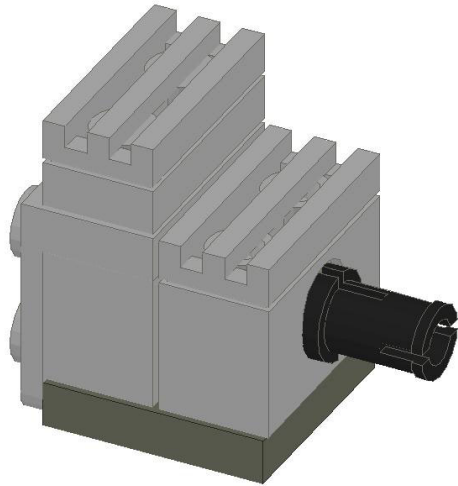

Now attach them to the main hull on each side.

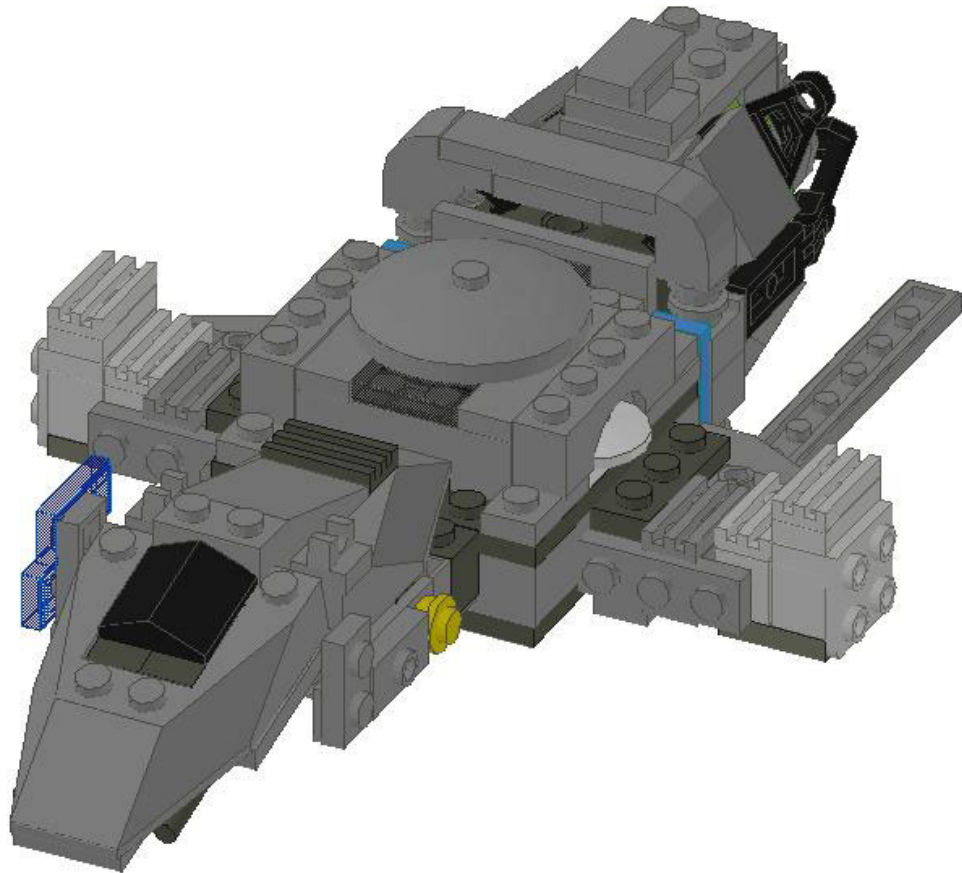

We're in the final stages now- we just have to assemble the side engines.

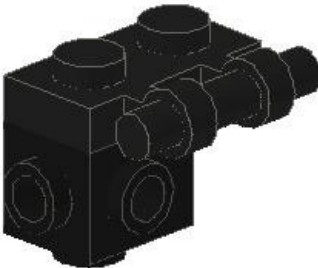

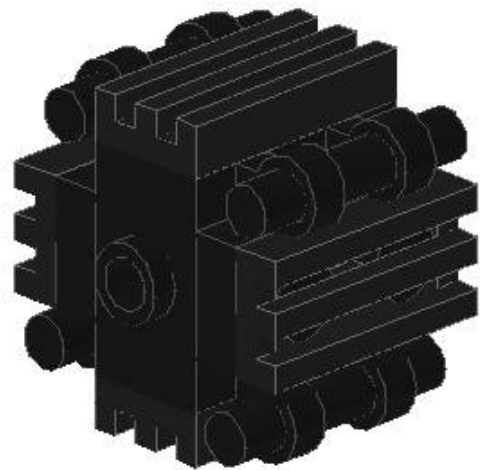
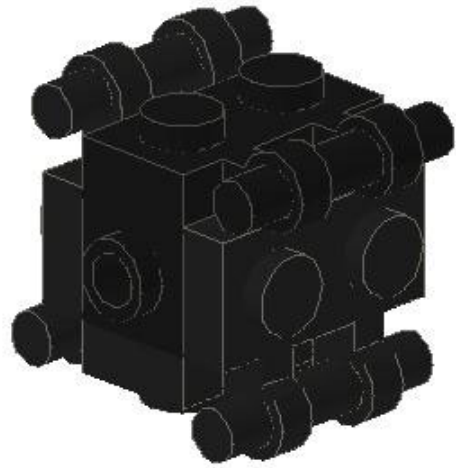

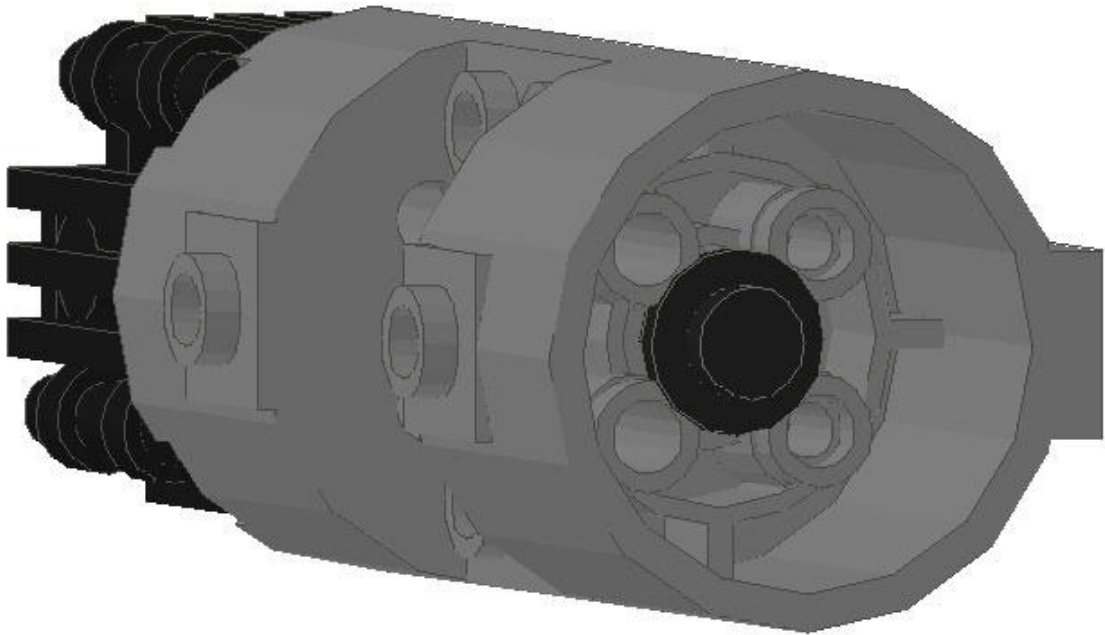
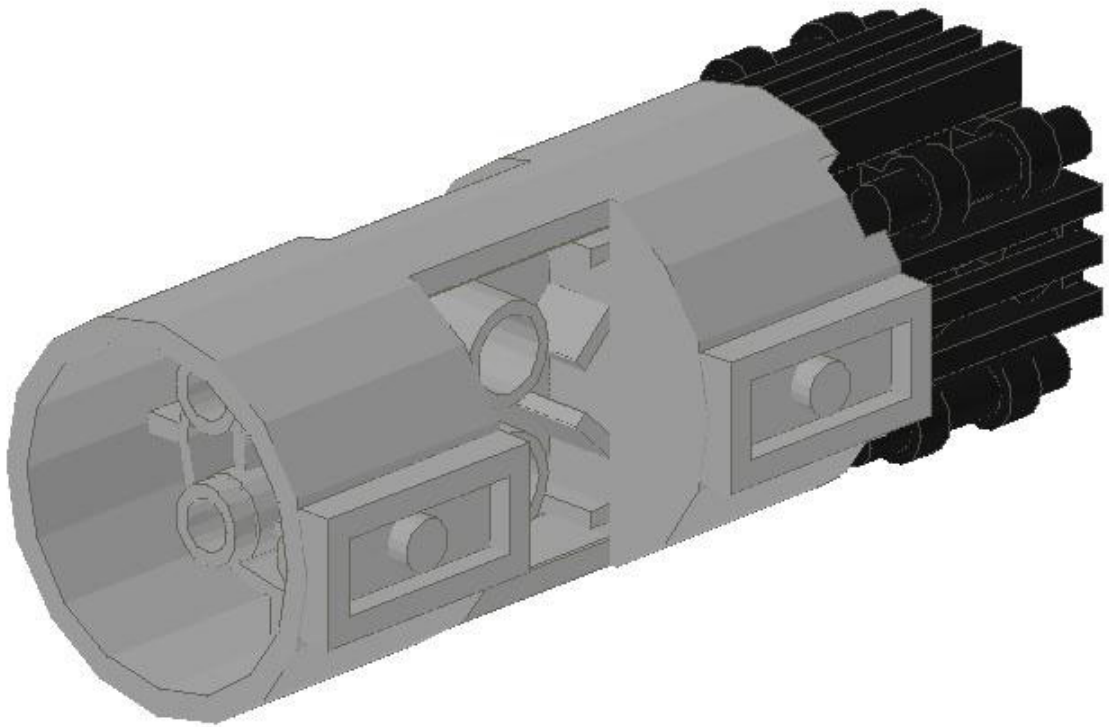

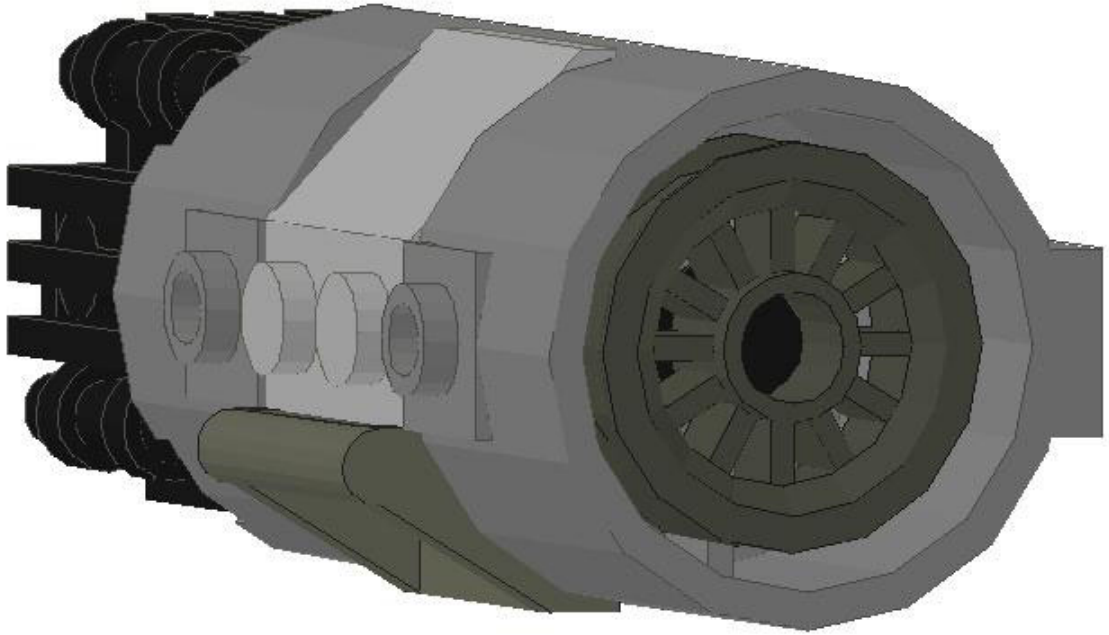
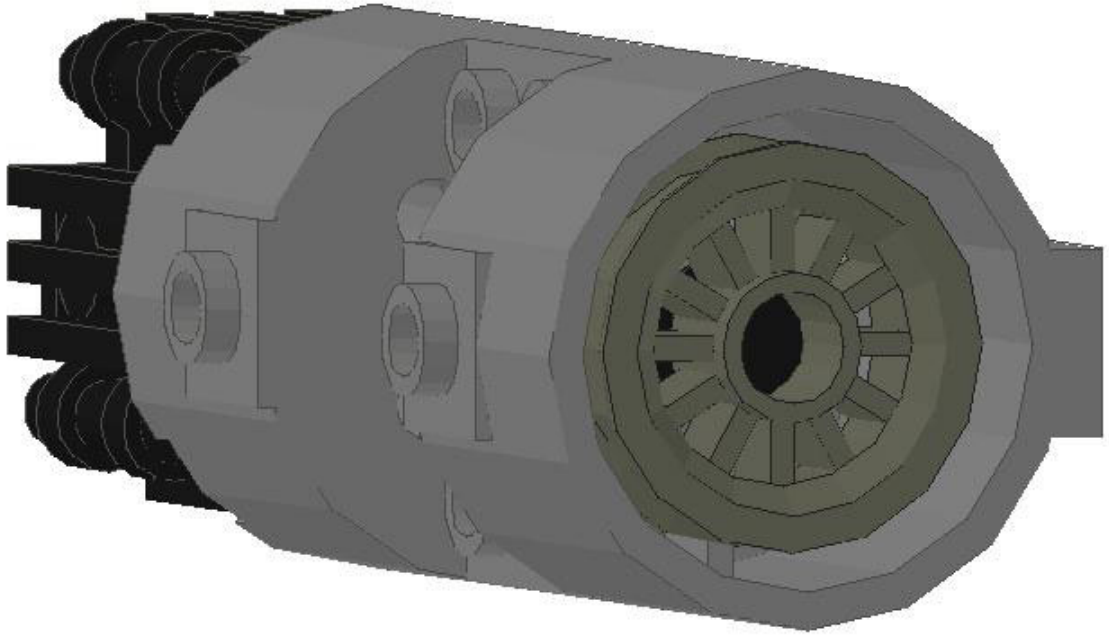

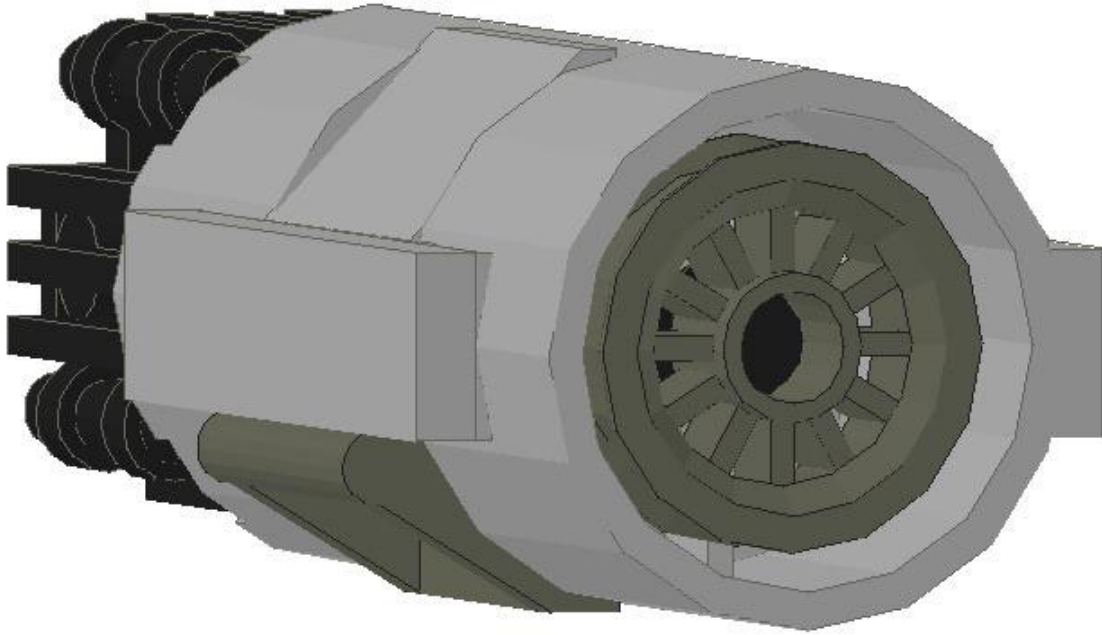

Just one more sub-assembly to go! We'll attach both of the side engines at the same time.



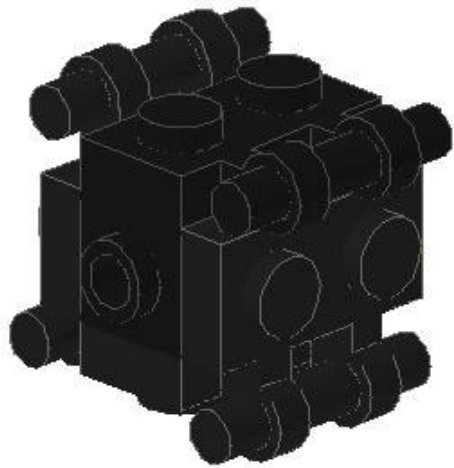
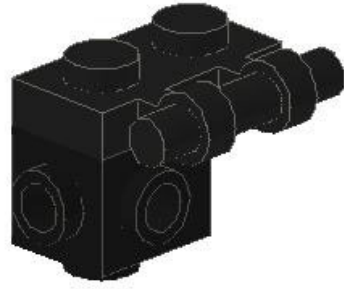

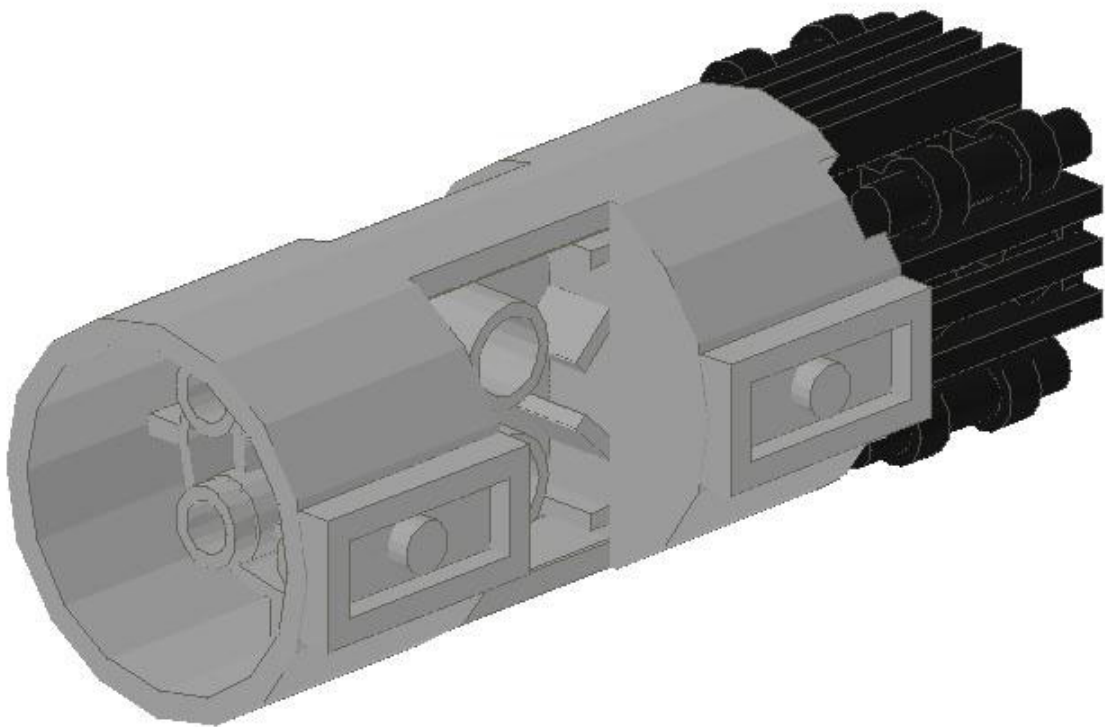
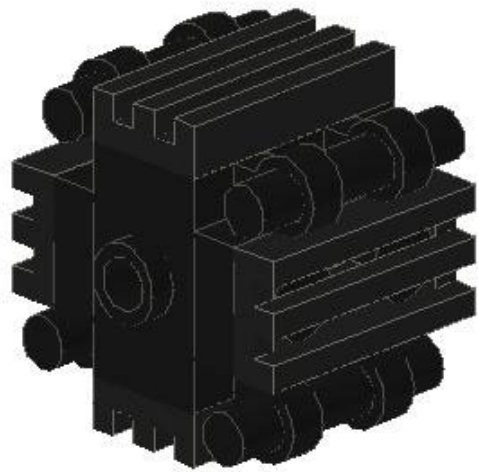

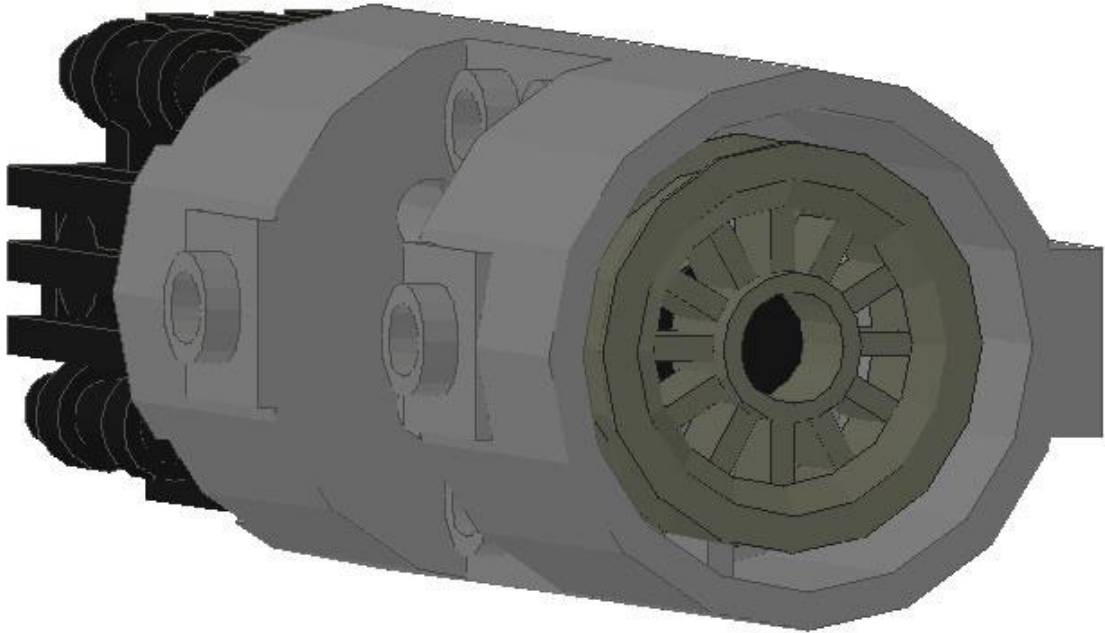
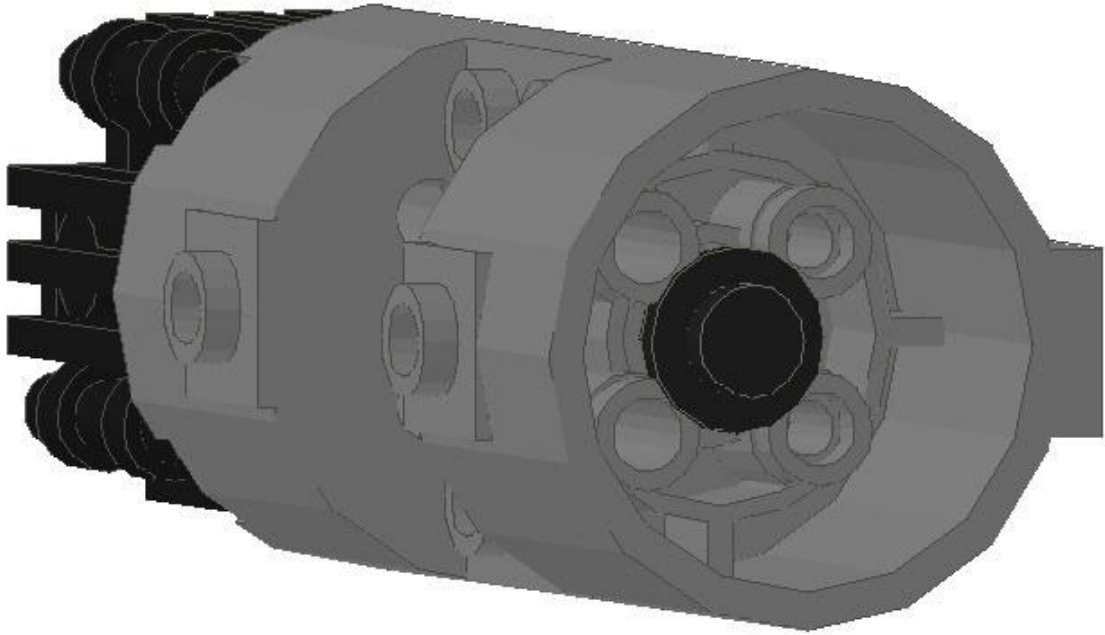

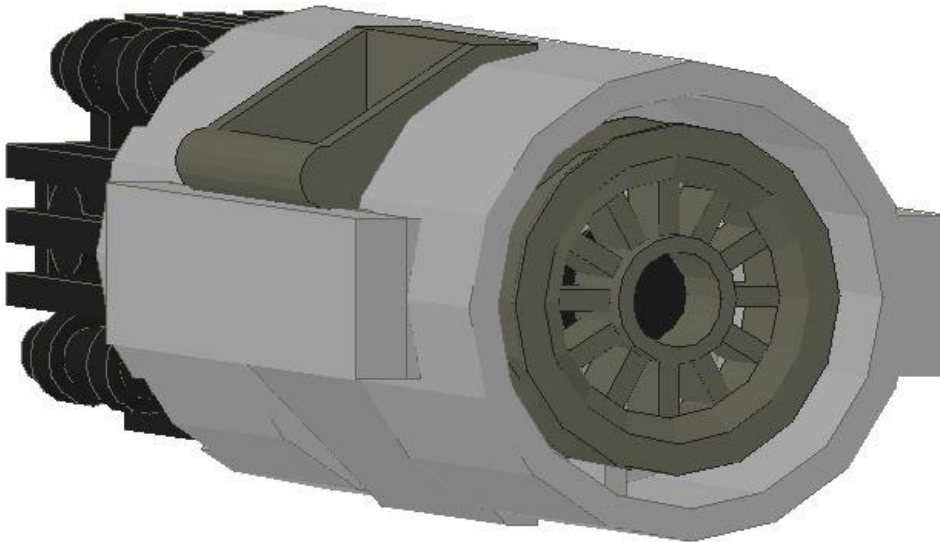
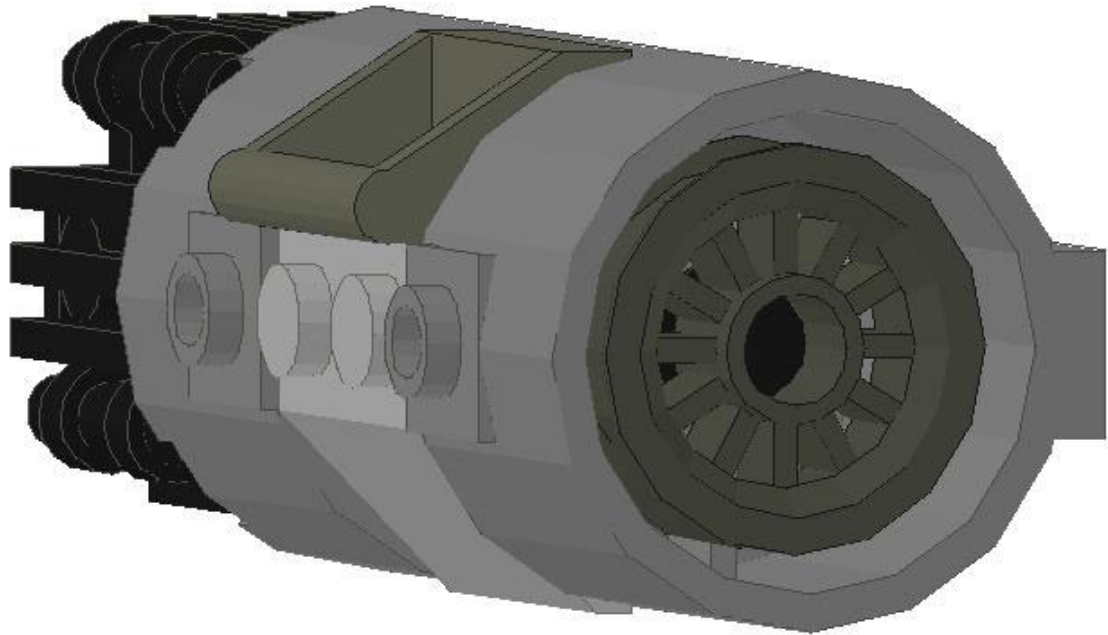

And now you'll all set for the final step! Snap the engines on and your model of Snack-Sized Serenity is now complete!

